

# ENGR 101 Engineering Technology

## Assignment 4

Due date: Wed, 12 June 2024 (23:59 hrs)

You must type your answers using a word processor or any other similar computer program. Save the computer file containing your answers as a pdf file using the filename format: **Student Id number-A4.pdf**. For example, 221249123-A4.pdf

1. Use the Boolean Laws discussed in lectures to simplify the following expressions:

- a)  $AB + AC + ABC$
- b)  $AB + A(B'+C) + ABC'$
- c)  $A'BC + AB'C + ABC + ABC' + A'B'C'$
- d)  $AB'C' + A'B'C' + A'BC' + A'B'C$

2. Simple logic functions.

Build each of the logic functions shown below using the circuit simulator (available from <https://www.falstad.com/circuit/>). Establish truth tables relating the inputs A and B to the output C for these circuits. Summarize the truth tables with algebraic expressions which reflect the relevant theorems of Boolean Algebra.

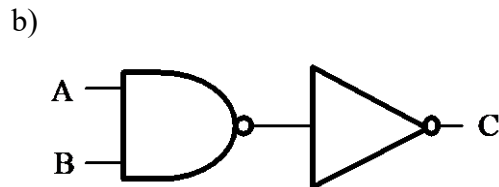
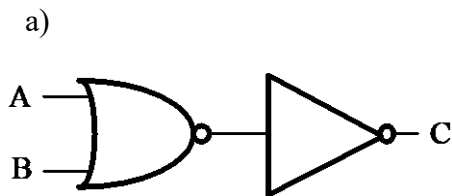

3. Build the two circuits shown below using the circuit simulator (available from <https://www.falstad.com/circuit/>). Write the truth tables for the two circuits. Write the Boolean Algebraic expressions for the outputs C in both cases and show them to be equal by reference to their truth tables.

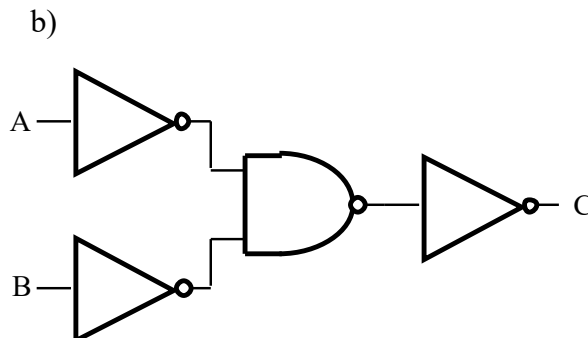
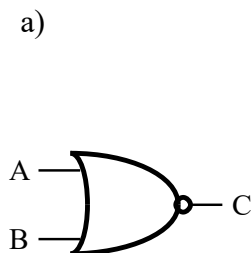

4. Study the two circuits shown below and answer the questions. The first circuit has two AND gates, an OR gate and an INVERTER.

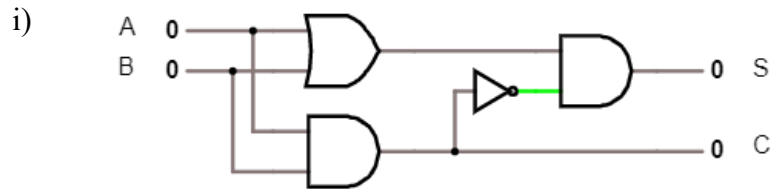

The second circuit has three NOR gates and two INVERTERS.

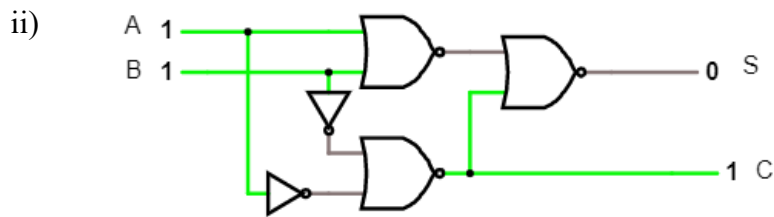

- Write the Boolean algebra expression for each logic circuit.
- Minimize each expression using the K-Map method.
- Construct the 2 logic circuits shown above using the circuit simulator (available from <https://www.falstad.com/circuit/>).
- Construct a truth table for each circuit.

| <b>A</b> | <b>B</b> | <b>S</b> | <b>C</b> |
|----------|----------|----------|----------|
| 0        | 0        |          |          |
| 0        | 1        |          |          |
| 1        | 0        |          |          |
| 1        | 1        |          |          |

- What conclusion can you make from the truth tables?