

XMUT 202

Digital Electronics

Felix Yan

School of Engineering and Computer Science
Victoria University of Wellington

Victoria
UNIVERSITY OF WELLINGTON

*Te Whare Wānanga
o te Ūpoko o te Ika a Māui*



CAPITAL CITY UNIVERSITY

Review of Logic Gates

- What is a **logic gate**?

Review of Logic Gates

- What is a **logic gate**?
 - An electronic component that can be used to conduct electricity based on a rule.

Review of Logic Gates

- What is a **logic gate**?
 - An electronic component that can be used to conduct electricity based on a rule.
 - The output of the logic gate is the result of applying this rule to one or more inputs.

Review of Logic Gates

- Assuming we understand the concept of binary numbers, we will study ways of describing how systems using binary logic levels make decisions.

Review of Logic Gates

- Assuming we understand the concept of binary numbers, we will study ways of describing how systems using binary logic levels make decisions.

- Boolean algebra is an important tool in describing, analyzing, designing, and implementing digital circuits.

Boolean Constants and Variables

- Boolean algebra allows only two values:
 - 0 and 1.

Boolean Constants and Variables

- Boolean algebra allows only two values; 0 and 1.
- Logic 0 can be:
 - false, off, low, no, open switch.

Boolean Constants and Variables

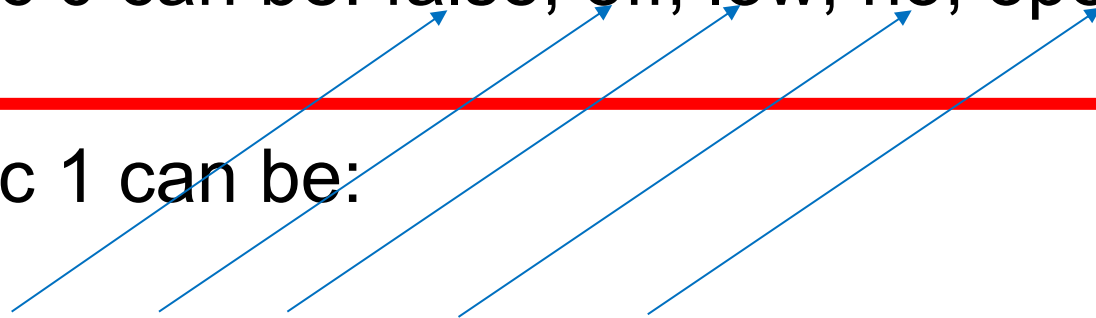
- Boolean algebra allows only two values; 0 and 1.
 - Logic 0 can be: false, off, low, no, open switch.
 - Logic 1 can be:
 - true, on, high, yes, closed switch.
- 

Boolean Constants and Variables

- Boolean algebra allows only two values; 0 and 1.
- Logic 0 can be: false, off, low, no, open switch.
- Logic 1 can be: true, on, high, yes, closed switch.
- Three basic logic operations: **OR**, **AND**, and **NOT**.

Truth Tables

- A truth table describes the relationship between the inputs and output of a logic circuit.

Truth Tables

- A truth table describes the relationship between the inputs and output of a logic circuit.

Inputs

Output

A	B	X
0	0	1
0	1	0
1	0	1
1	1	0

Truth Tables

- The number of entries corresponds to the number of inputs.

Truth Tables

- The number of entries corresponds to the number of inputs.
 - A 2 inputs table should have 2^2 or 4 entries.

Truth Tables

- The number of entries corresponds to the number of inputs.
 - A 2 inputs table would have 2^2 or 4 entries.

Number of inputs = 2

Number
of
entries
= $2^2 = 4$

A	B	X
0	0	1
0	1	0
1	0	1
1	1	0

Truth Tables

- The number of entries corresponds to the number of inputs.
 - A 3 inputs table will have 2^3 or 8 entries.

Number of inputs = 3

Number
of
entries
= $2^3 = 8$

A	B	C	X
0	0	0	0
0	0	1	1
0	1	0	1
0	1	1	1
1	0	0	0
1	0	1	1
1	1	0	0
1	1	1	1

Truth Tables

- Truth table with 4 inputs.

Number of inputs = 4

Number
of
entries
= $2^4 = 16$

A	B	C	D	x
0	0	0	0	0
0	0	0	1	0
0	0	1	0	0
0	0	1	1	1
0	1	0	0	1
0	1	0	1	0
0	1	1	0	0
0	1	1	1	1
1	0	0	0	0
1	0	0	1	0
1	0	1	0	0
1	0	1	1	1
1	1	0	0	0
1	1	0	1	0
1	1	1	0	0
1	1	1	1	1

1) OR operation with OR Gate

- The Boolean expression for the

OR operation is $X = A + B$

1) OR operation with OR Gate

- The Boolean expression for the OR operation is $X = A + B$

- This is read as “x equals A or B.”
- X will equal 1 when A or B equals 1.

1) OR operation with OR Gate

- The Boolean expression for the OR operation is $X=A+B$
 - This is read as “x equals A or B.”
 - X will equal 1 when A or B equals 1.

- Truth table for a two inputs OR gate.

OR

A	B	$x = A + B$
0	0	0
0	1	1
1	0	1
1	1	1

1) OR operations with OR Gate

- Truth table for a two inputs OR gate.
 - X will equal 1 when A or B equals 1

A	B	$X = A + B$
0	0	$X = 0 + 0 = 0$

1) OR operations with OR Gate

- Truth table for a two inputs OR gate.
 - X will equal 1 when A or B equals 1

A	B	$X = A + B$
0	0	$X = 0 + 0 = 0$
0	1	$X = 0 + 1 = 1$

1) OR operations with OR Gate

- Truth table for a two inputs OR gate.
 - X will equal 1 when A or B equals 1

A	B	$X = A + B$
0	0	$X = 0 + 0 = 0$
0	1	$X = 0 + 1 = 1$
1	0	$X = 1 + 0 = 1$

1) OR operations with OR Gate

- Truth table for a two inputs OR gate.
 - X will equal 1 when A or B equals 1

A	B	$X = A + B$
0	0	$X = 0 + 0 = 0$
0	1	$X = 0 + 1 = 1$
1	0	$X = 1 + 0 = 1$
1	1	$X = 1 + 1 = 1$

1) OR operation with OR Gate

- Truth table and circuit symbol for a two input OR gate.

OR

A	B	$x = A + B$
0	0	0
0	1	1
1	0	1
1	1	1

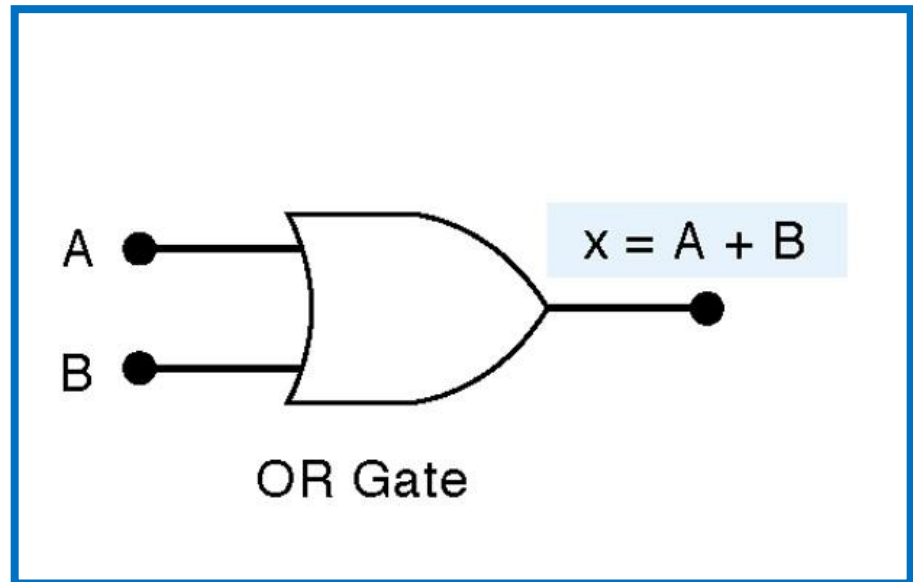

1) OR Operation With OR Gates

- The OR operation is similar to addition but when A and B are 1, the OR operation produces $1 + 1 = 1$.

1) OR Operation With OR Gates

- The OR operation is similar to addition but where A and B are 1, the OR operation produces $1 + 1 = 1$.

- In the Boolean expression

$$X = 1 + 1 + 1 = 1$$

We could say that x is true (1) when A is true (1) OR B is true (1) OR C is true (1).

1) OR Operation With OR Gates

- There are many examples of applications where an output function is desired when one of multiple inputs is activated.

1) OR Operation With OR Gates

- There are many examples of applications where an output function is desired when one of multiple inputs is activated.

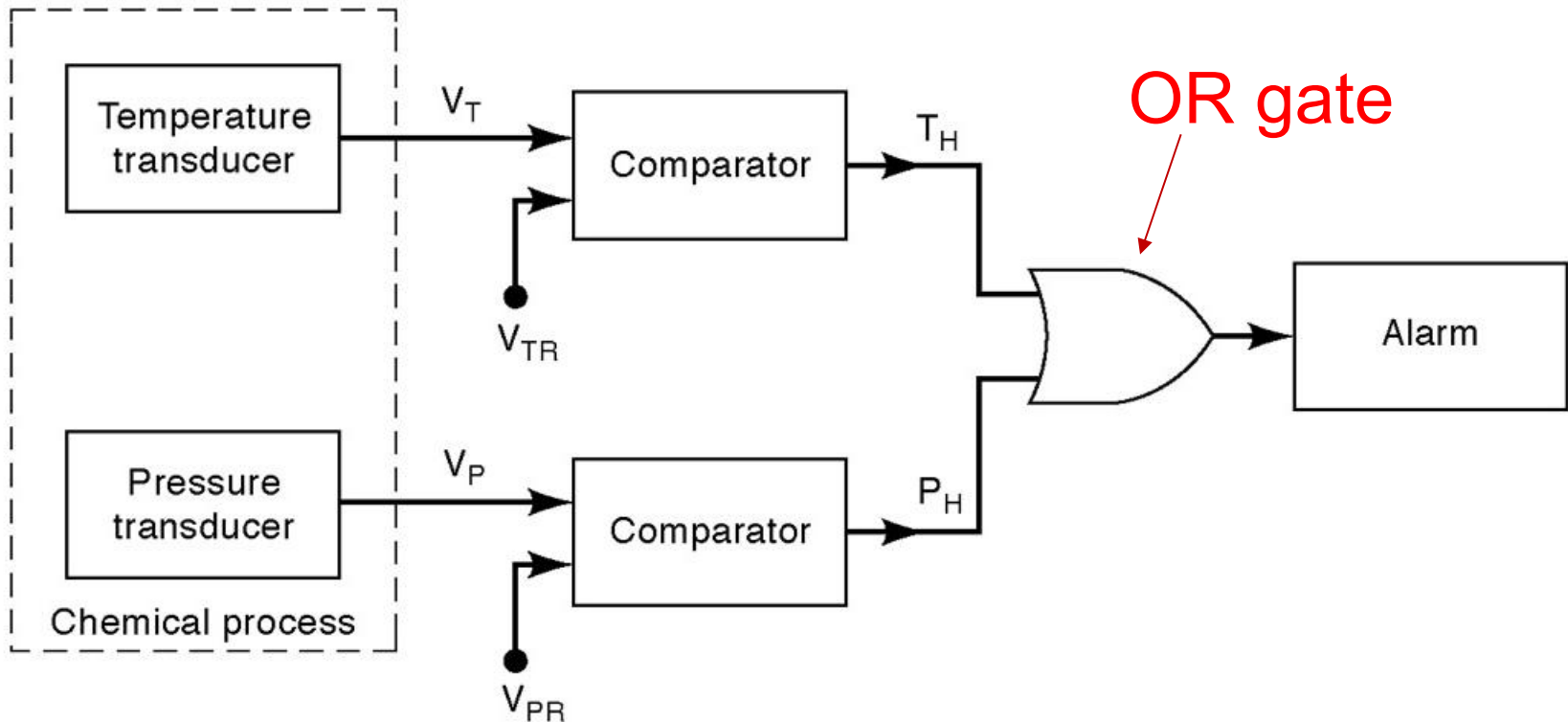

Representing Logic Functions by Timing Diagrams

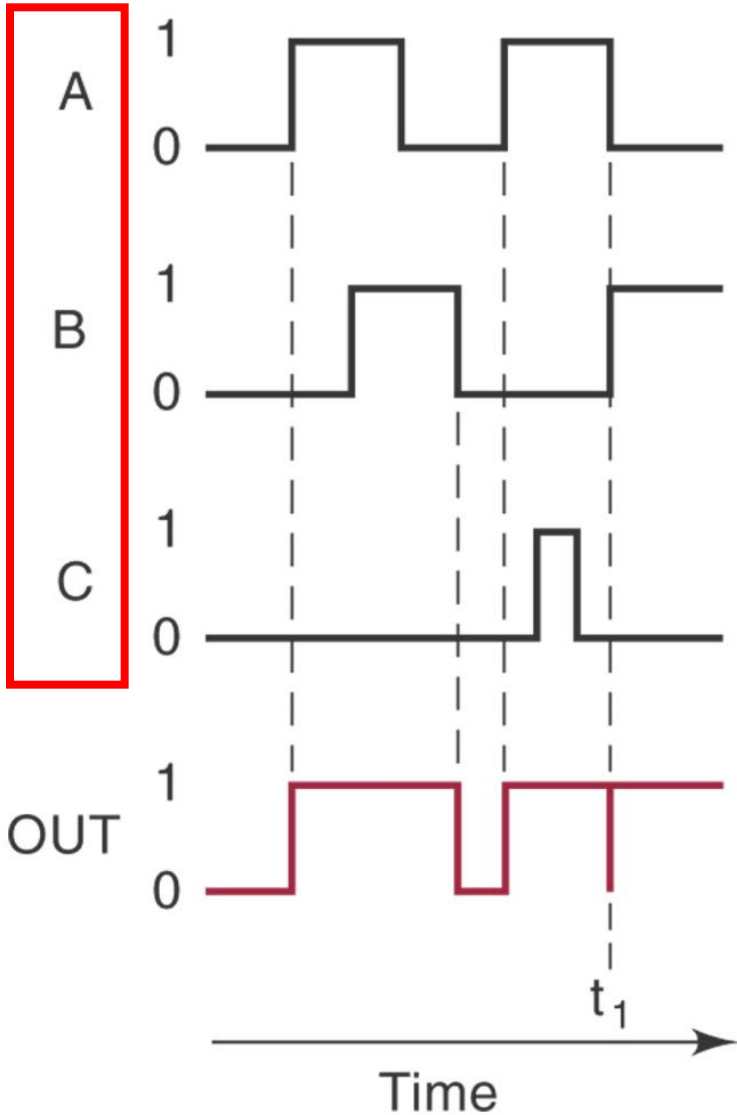

Representing Logic Functions by Timing Diagrams

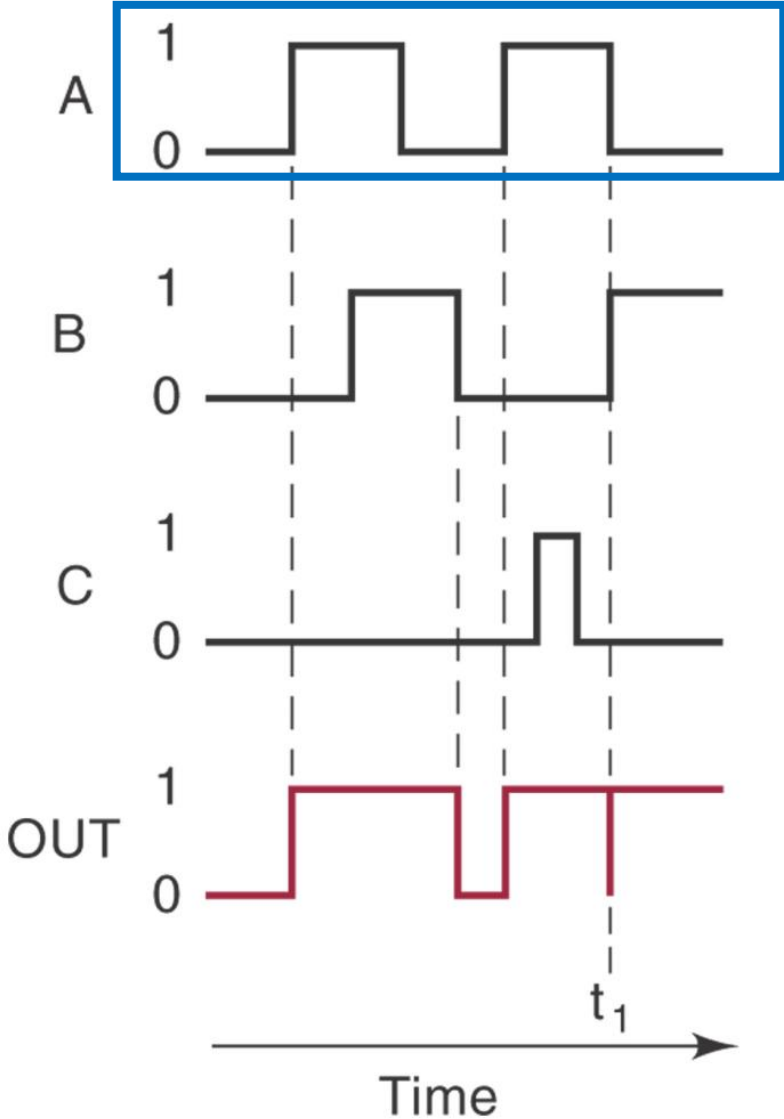

Representing Logic Functions by Timing Diagrams

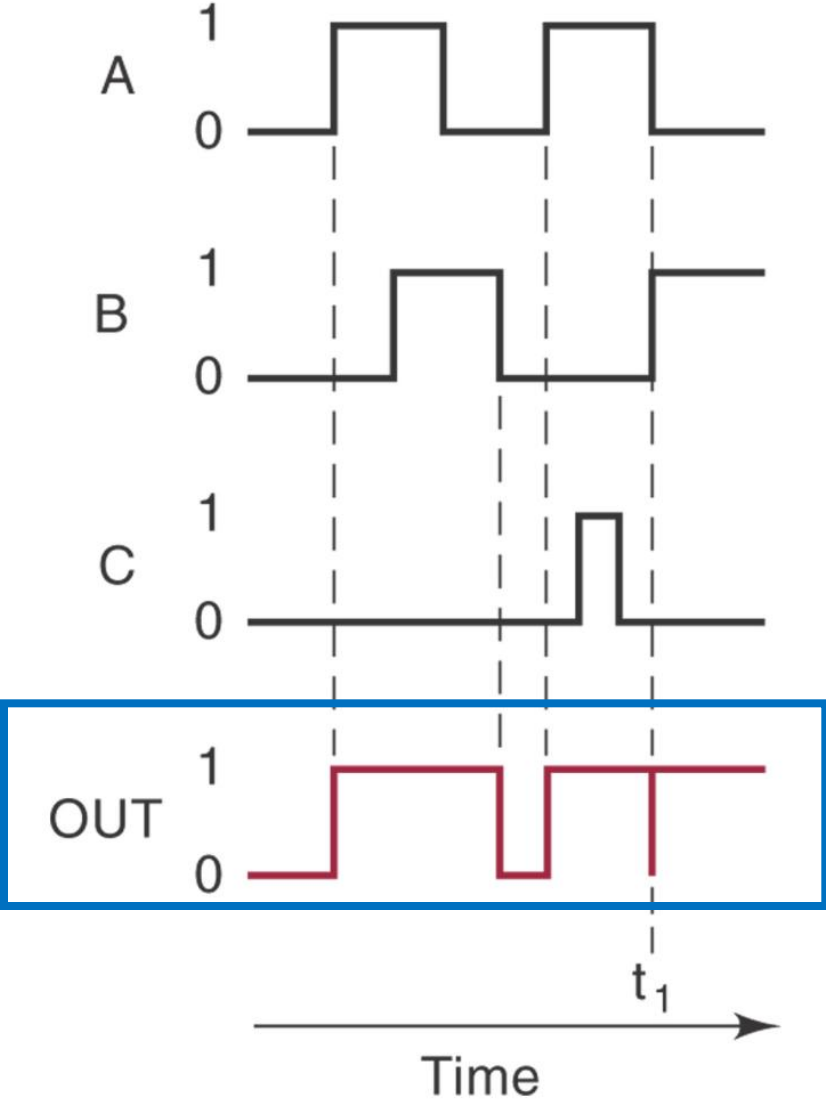

Representing Logic Functions by Timing Diagrams

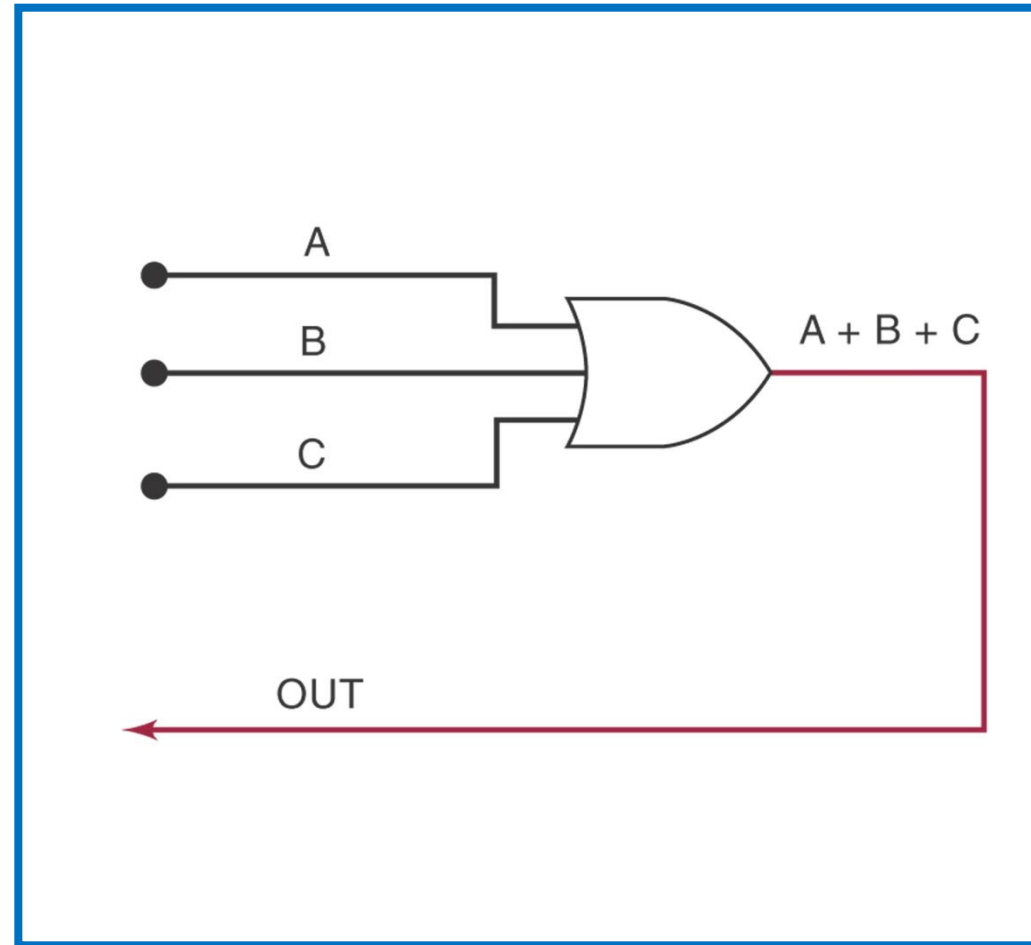
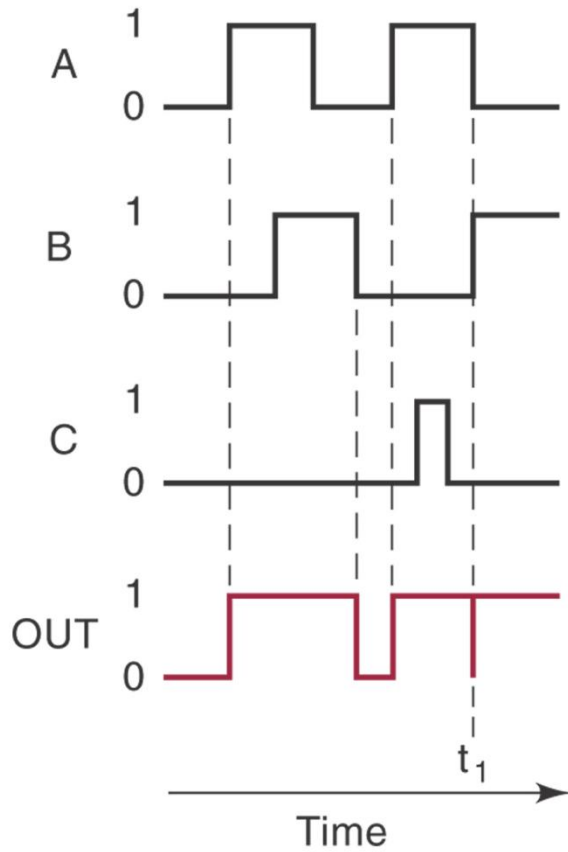

2) AND Operations with AND gate

- The Boolean expression for the AND operation is

$$X = A \cdot B$$

- This is read as “x equals A and B.”
- x will equal 1 when A and B equal 1.

2) AND Operations with AND gate

- The Boolean expression for the AND operation is

$$X = A \cdot B$$

- This is read as “x equals A and B.”
- x will equal 1 when A and B equal 1.

- Truth table for a two inputs AND gate. Note the difference between OR and AND gates.

AND

A	B	$x = A \cdot B$
0	0	0
0	1	0
1	0	0
1	1	1

2) AND Operations with AND gate

- The Boolean expression for the AND operation is
$$X = A \cdot B$$
 - This is read as “x equals A and B.”
 - x will equal 1 when A and B equal 1.
- Truth table and circuit symbol for a two input AND gate. Note the difference between OR and AND gates.

AND

A	B	$x = A \cdot B$
0	0	0
0	1	0
1	0	0
1	1	1

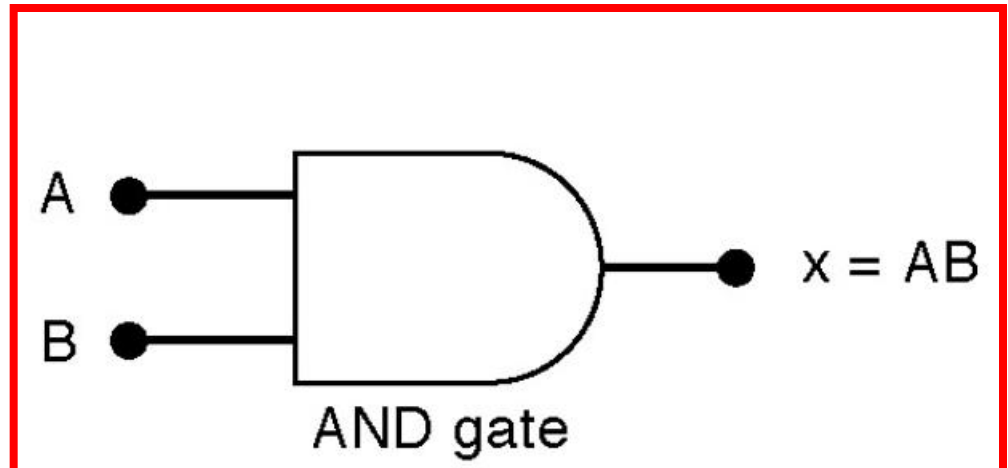

2) AND Operation With AND Gates

- The AND operation is similar to multiplication.
- In the Boolean expression

$$X = A \cdot B \cdot C$$

x will equal 1 only when A, B, and C are all 1.

3) NOT Operation

- The Boolean expression for the NOT operation is

$$x = \bar{A}$$

3) NOT Operation

- The Boolean expression for the NOT operation is

$$x = \overline{A}$$

- This is read as:
 - x equals NOT A, or
 - x equals the inverse of A, or
 - x equals the complement of A

3) NOT Operation

- Truth table, symbol, and sample waveform for the NOT circuit.

NOT

A	$x = \bar{A}$
0	1
1	0

(a)

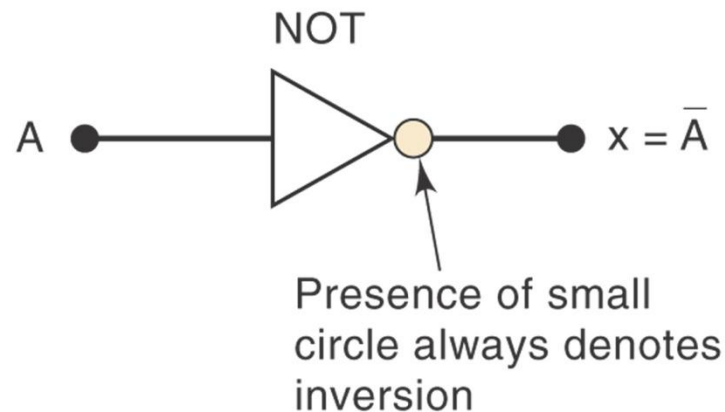

(b)

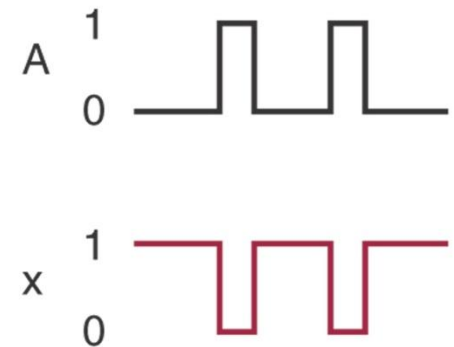

(c)

Describing Logic Circuits Algebraically

- The three basic Boolean operations (OR, AND, NOT) can describe any logic circuit.

Describing Logic Circuits Algebraically

Example 1: Boolean expression for a logic circuit

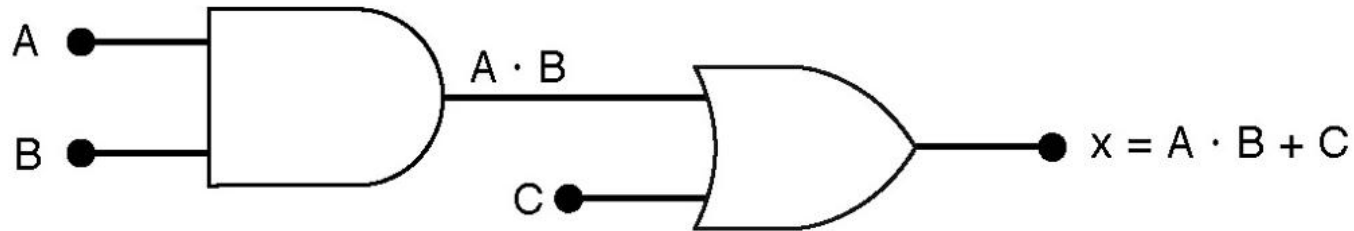

Describing Logic Circuits Algebraically

Example 1: Boolean expressions for a logic circuit:

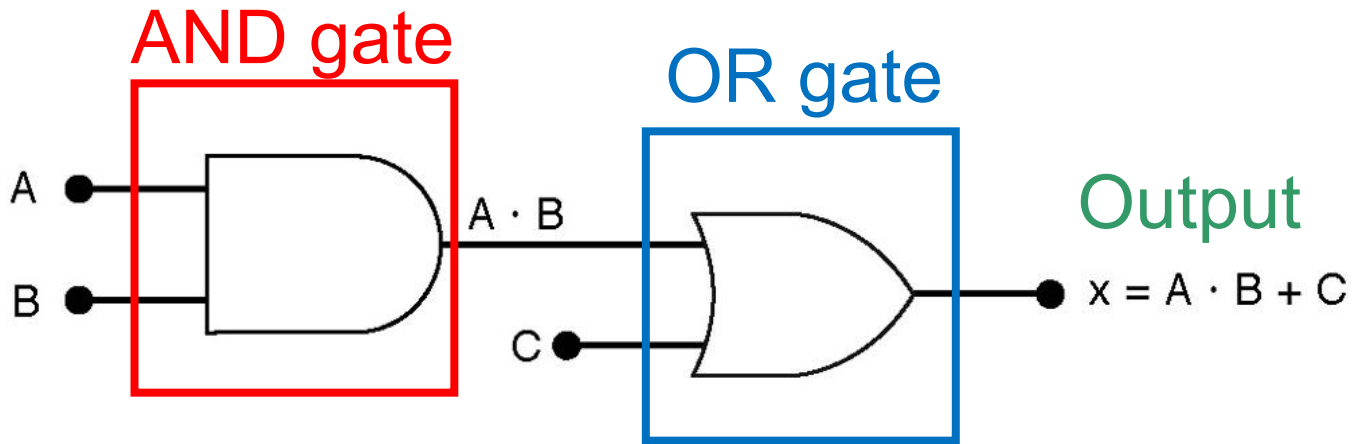

Describing Logic Circuits Algebraically

Example 2: Boolean expressions for logic circuits:

Parentheses or brackets ()

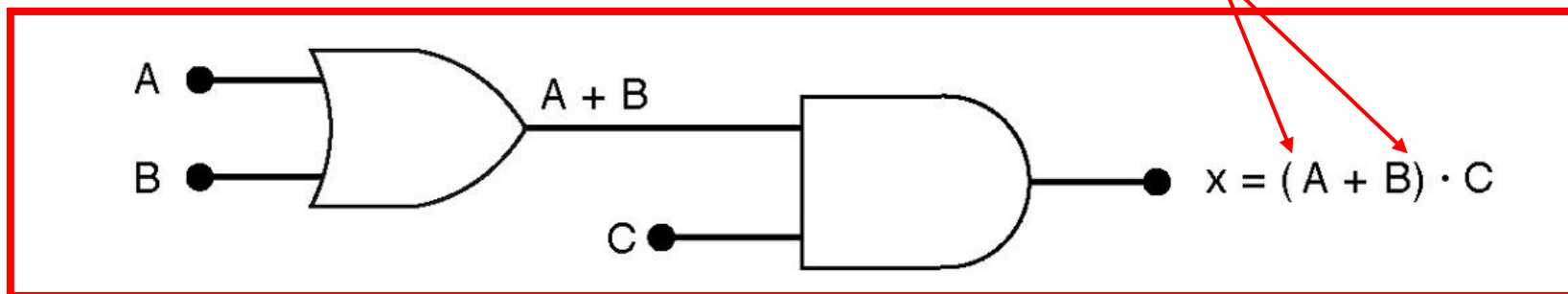

Example 1:

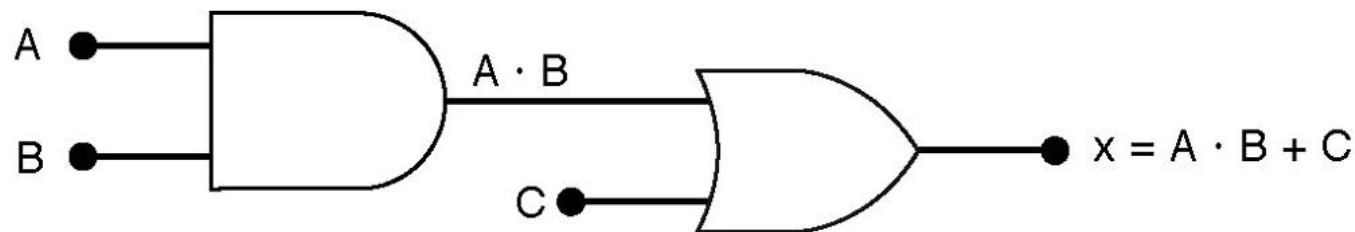

Describing Logic Circuits Algebraically

- The output of an inverter is equivalent to the input with a bar over it.
- Input A through an inverter is \bar{A}
- Example using inverters.

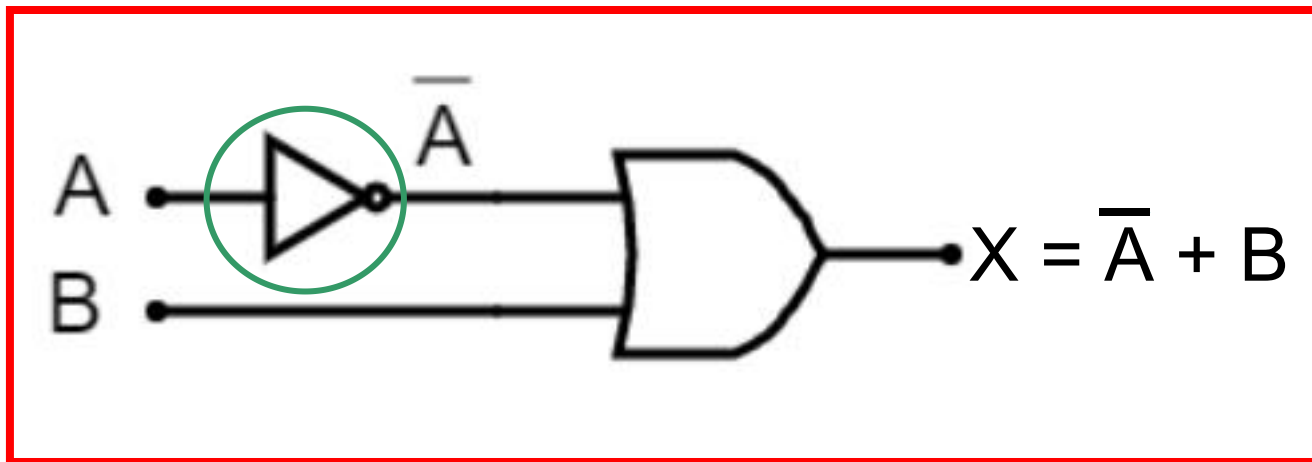

Describing Logic Circuits Algebraically

- A second example

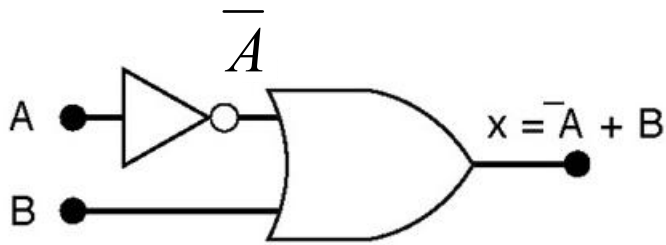

(a)

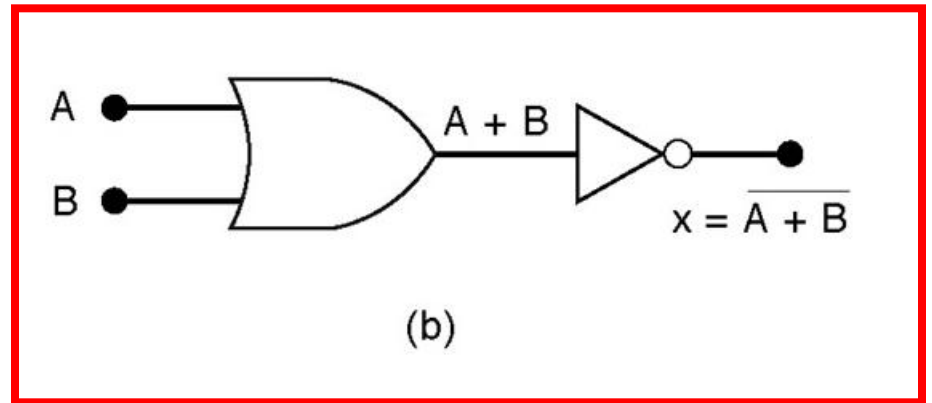

(b)

Evaluating Logic Circuit Outputs

Example 1: Complete the truth table for the given circuit.

Logic circuit

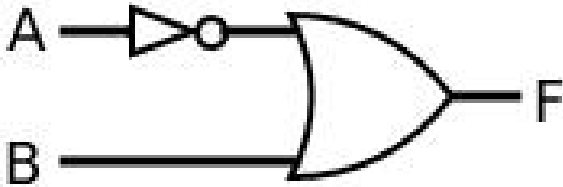

Truth table

A	B	F
0	0	
0	1	
1	0	
1	1	

Evaluating Logic Circuit Outputs

Example 1: Complete the truth table for the given circuit.

Logic circuit

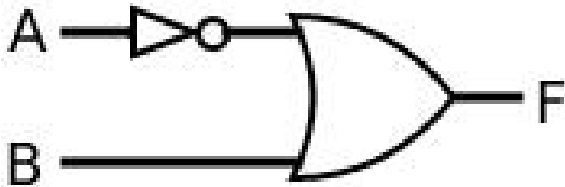

Truth table

A	B	F
0	0	1
0	1	1
1	0	0
1	1	1

Evaluating Logic Circuit Outputs

Exercise 1: Complete the truth table for the given circuit.

Logic circuit

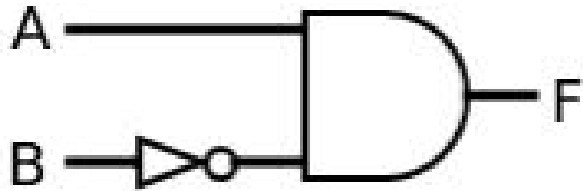

Truth table

A	B	F
0	0	0
0	1	0
1	0	1
1	1	0

Evaluating Logic Circuit Outputs

Rules for evaluating a Boolean expression:

1. Perform all inversions of single terms.
2. Perform all operations within **parenthesis**.
3. Perform AND operation before an OR operation unless parenthesis indicate otherwise.
4. If an expression has a bar over it, perform the operations inside the expression and then invert the result.

Evaluating Logic Circuit Outputs

Exercise 2:

- Evaluate the given Boolean expression by substituting values and performing the indicated operations.

$$A = 0, B = 1, C = 1, \text{ and } D = 1$$

$$X = \overline{A}BC \overline{(A + D)}$$

Evaluating Logic Circuit Outputs

- Evaluate Boolean expressions by substituting values and performing the indicated operations:

$$A = 0, B = 1, C = 1, \text{ and } D = 1$$

$$x = \overline{A}BC \overline{(A + D)}$$

Solution:

$$\text{Rule 1} \longrightarrow x = \overline{0} \cdot 1 \cdot 1 \cdot \overline{(0 + 1)}$$

$$\text{Rule 2} \longrightarrow = 1 \cdot 1 \cdot 1 \cdot \overline{(0 + 1)}$$

$$\text{Rule 1} \longrightarrow = 1 \cdot 1 \cdot 1 \cdot (\overline{1})$$

$$\text{Rule 3} \longrightarrow = 1 \cdot 1 \cdot 1 \cdot 0$$

$$x = 0$$

Evaluating Logic Circuit Outputs

Exercise 2:

- Evaluate the given Boolean expression by substituting values and performing the indicated operations.

$$A = 1, B = 0, C = 0 \text{ and } D = 0$$

$$X = \overline{A}BC \overline{(A + D)}$$

You have 2 minutes to determine the answer!

Evaluating Logic Circuit Outputs

Exercise 2:

- Evaluate the given Boolean expression by substituting values and performing the indicated operations.

$$A = 1, B = 0, C = 0 \text{ and } D = 0$$

$$x = \overline{A}BC \overline{(A + D)}$$

$$= \overline{1}.0.0.\overline{(1+0)}$$

$$= 0.0.0.\overline{(1)}$$

$$= 0.0.0.0$$

$$= 0$$

Evaluating Logic Circuit Outputs

- Output logic levels can be determined directly from a circuit diagram.
- The output of each gate is noted until a final output is found.

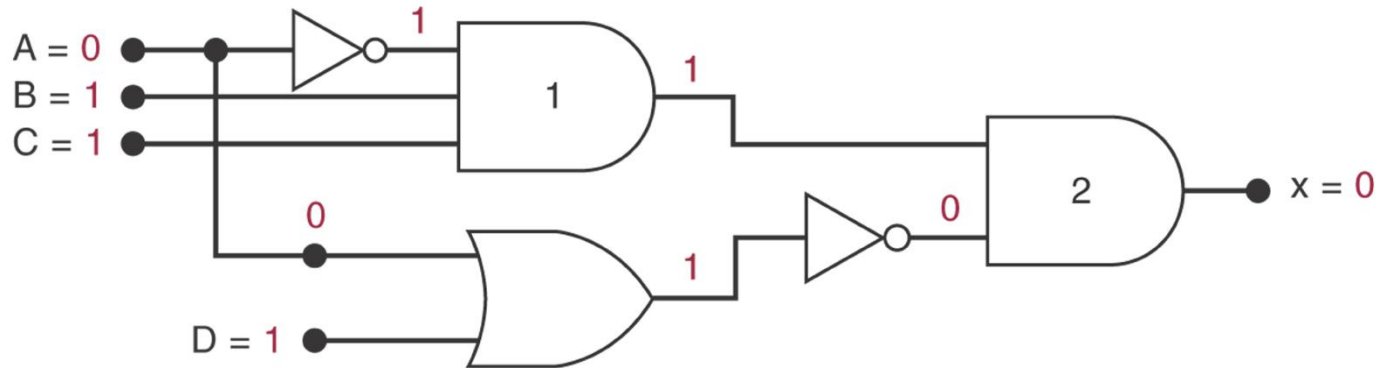

Evaluating Logic Circuit Outputs

Exercise 3:

Evaluate the output F for the given logic circuit when $A = 0$; $B = 1$; and $C = 1$.

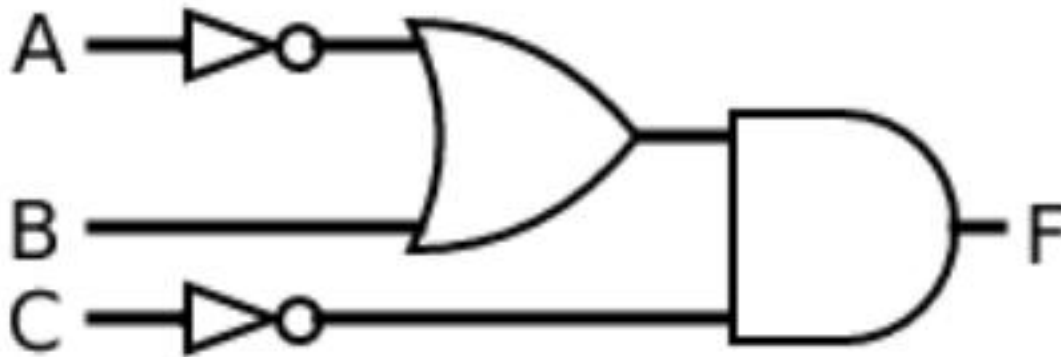

You have 2 minutes to determine the answer!

Evaluating Logic Circuit Outputs

Exercise 3:

Evaluate the output F for the given logic circuit when $A = 0$; $B = 1$; and $C = 1$.

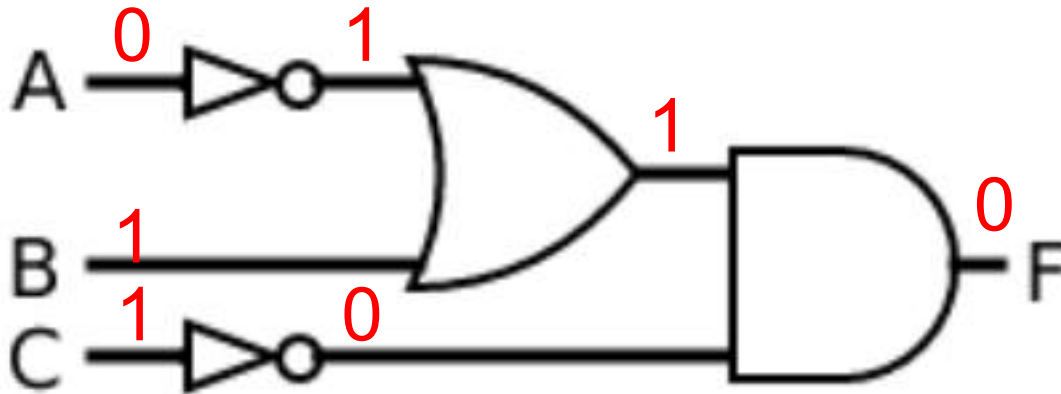

Evaluating Logic Circuit Outputs

Exercise 4 (live):

Evaluate the output F for the given logic circuit when

$A = 1; B = 0; C = 0$

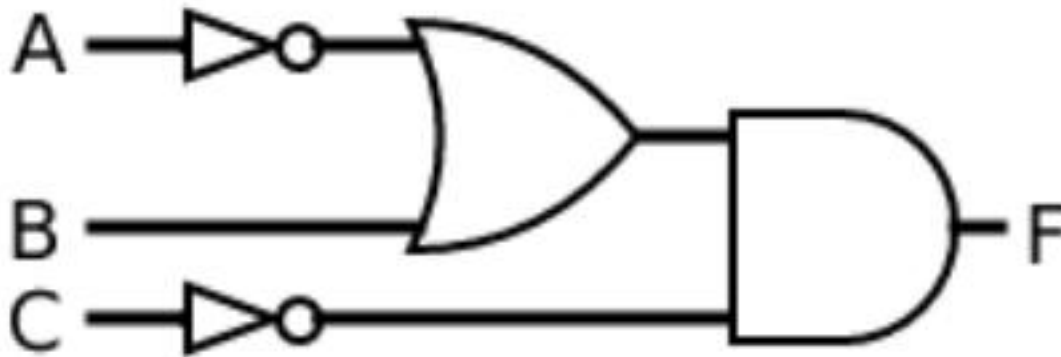

You have 2 minutes to determine the answer!

Evaluating Logic Circuit Outputs

Exercise 4 (live):

Evaluate the output F for the given logic circuit when

$A = 1; B = 0; C = 0$

