

XMUT202 Digital Electronics

Tutorial 2: Microcontroller Components and Operations (Solution)

A. Microcontroller Components and Operations

1. Using as a reference the diagram of microcontroller and its peripherals given below, describe briefly at least four most common components of microcontroller in general. [2 marks]

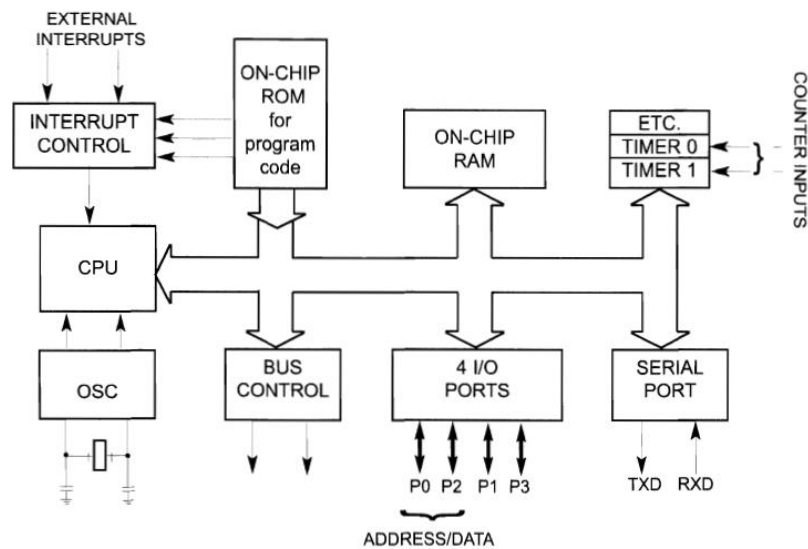

Solution

These are any four of the following components:

- CPU: Process the instruction and data.
- Oscillator (clock): Provide timing for the processing.
- Memory: Store program and data (i.e. RAM, ROM, etc.)
- Timer: Accumulates clock pulses to measure elapsed time or count events.
- Ports: Transfer data from/to the external parts (i.e. parallel and serial ports).
- Interrupts: Service the internal/external events or devices.

2. Describe the function of accumulator in the 8051 microcontrollers.

[2 marks]

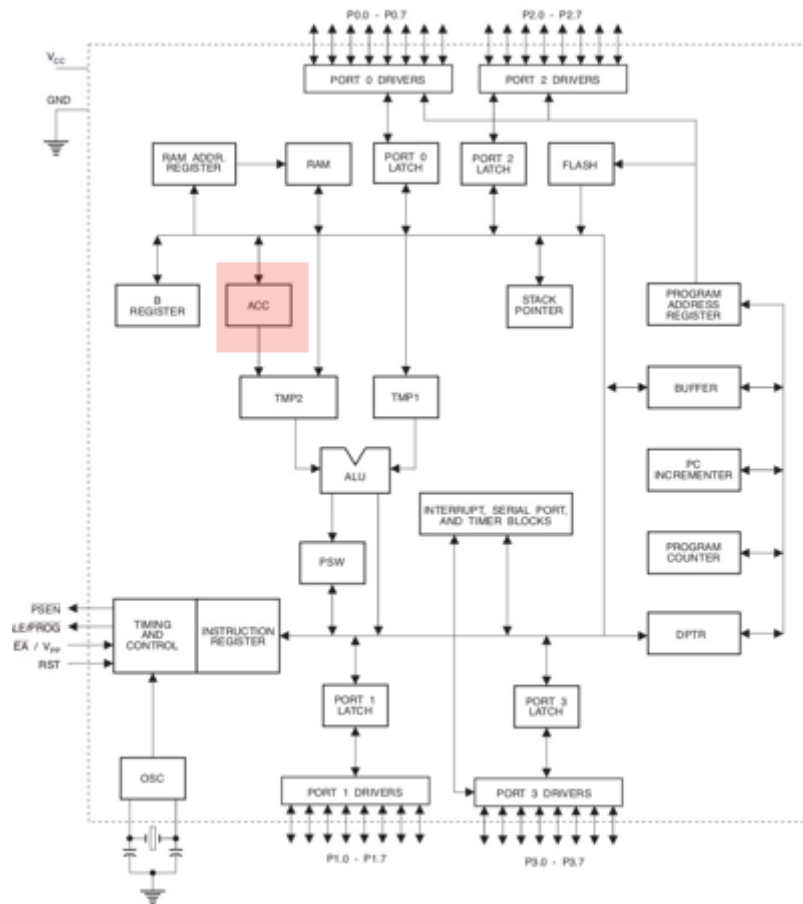

Solution

Accumulator (ACC) is often referred to as Register A which is 8-bit (1 byte) wide register. This is where the results of ALU operations are stored. Many instructions on the 8051 make use of the A register. The values in the accumulator may be further processed (sent back to the ALU, etc.). The accumulator value may also be stored to other memory locations.

B. 8051 Microcontrollers

1. What are the features of 8051 microcontrollers? Provide at least 4 of them. [2 marks]

Solution

Features of 8051 microcontroller are given as follows:

- 8-bit CPU.
- 16-bit Program Counter.
- 8-bit Processor Status Word (PSW).
- 8-bit Stack Pointer.
- Internal RAM of 128 bytes.
- Special Function Registers (SFRs) of 128 bytes.

- 32 I/O pins arranged as four 8-bit ports (P0 - P3).
- Two 16-bit timer/counters (T0 and T1).
- Two external and three internal vectored interrupts.
- One full duplex serial I/O.

2. Give the PIN details of an 8051 microcontroller and explain.

[10 marks]

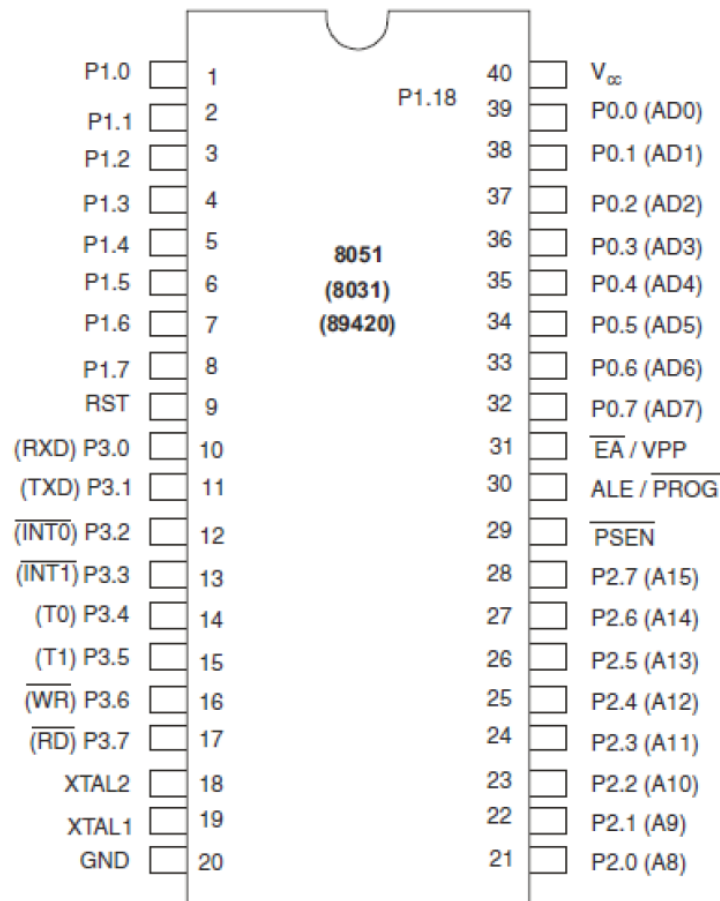

Solution

Pins 1-8: Port 1 Each of these pins can be configured as an input or an output.

Pin 9: RS A logic one on this pin disables the microcontroller and clears the contents of most registers.

Pins 10-17: Port 3 Similar to port 1, each of these pins can serve as general input or output.

Pin 10: RXD Serial asynchronous communication input or serial synchronous communication output.

Pin 11: TXD Serial asynchronous communication output or serial synchronous communication clock output.

Pin 12: INT0 Interrupt 0 input.

Pin 13: INT1 Interrupt 1 input.

Pin 14: T0 Counter 0 clock input.

Pin 15: T1 Counter 1 clock input.

Pin 16: WR Write to external (additional) RAM.

Pin 17: RD Read from external RAM.

Pin 18, 19: X2, X1 Internal oscillator input and output.

Pin 20: GND Ground.

Pin 21-28: Port 2 If there is no intention to use external memory then these port pins are configured as general inputs/outputs.

Pin 29: PSEN If external ROM is used for storing program, then a logic zero (0) appears on it every time the microcontroller reads a byte from memory.

Pin 30: ALE Prior to reading from external memory, the microcontroller puts the lower address byte (A0-A7) on P0 and activates the ALE output.

Pin 31: EA By applying logic zero to this pin, P2 and P3 are used for data and address transmission with no regard to whether there is internal memory or not

Pin 32-39: Port 0 Similar to P2, if external memory is not used, these pins can be used as general inputs/outputs.

Pin 40: VCC +5V power supply.

3. Referring to its internal block schematic given below, explain the internal components that are part of the architecture of 8051 microcontroller. [4 marks]

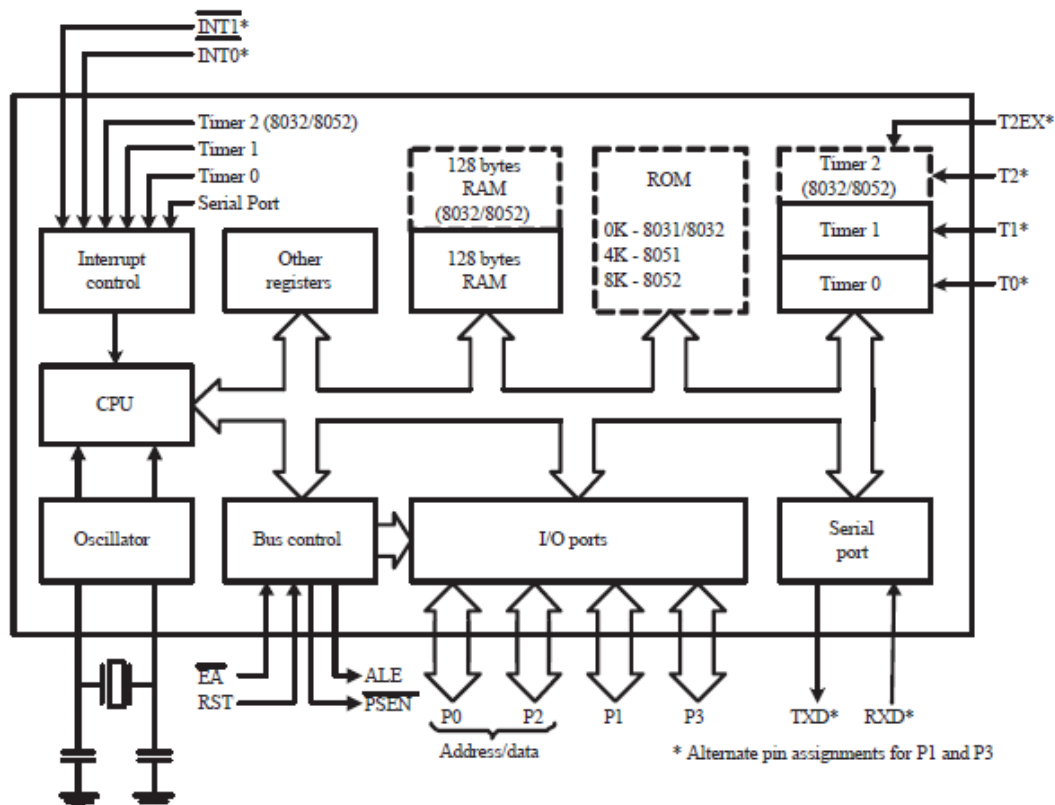

Solution

The internal components as illustrated in the block diagram of the 8051 microcontrollers architecture are as follows:

Oscillator

It requires a timer to function because the microcontroller is a digital device. An on-chip oscillator is externally linked or connected for the microcontroller to execute timer functions. An embedded system is used a microcontroller to control device functionality. The two 16-bit counters and timers are operated by the 8051. The oscillator inside the microcontroller is utilized to operate the timers and counters.

CPU

The central processing unit, or CPU, functions as any processing machine's brain. It coordinates and oversees every operation performed by the microcontroller. The user has no control over how the CPU operates. It executes from storage, interprets the program that is kept in ROM, and then carries out its intended function. The CPU controls the many register types that the 8051 microcontroller has to offer.

Interrupts: The interrupt subroutine is called by the microcontroller when a high-priority program requests to access the system buses. This causes interruptions in the program that is now executing. An interrupt can be used to delay the present process using timer. In order to complete a subroutine task and then resume the main program. Different 8051 microcontroller interrupt types:

- Timer 0 overflow interrupt (TF0)
- Timer 1 overflow interrupt (TF1)
- External hardware interrupt (INT0)
- External hardware interrupt (INT1)
- Serial communication interrupt (RI/TI)

Memory

To do an operation, microcontrollers need a program. The tasks that the microcontroller is supposed to accomplish are guided by this program. A portion of the on-chip memory was needed for the microcontroller's installed program to be stored. Memory was also needed by the microcontroller to store operands and data for brief periods of time. In addition to 128 bytes of data memory (RAM), the microcontroller 8051 includes 4 KB of code or program memory, or 4 KB ROM.

Bus

A Bus is a collection of wires that is used as a data transfer or communication channel. Eight, sixteen, or more cables are included in the various bus arrangement. As a result, a bus can support 8 bits, or 16 bits total. Bus types in an 8051 microcontroller:

- Address Bus: The 16-bit address bus is a component of 8051 microcontrollers. Transferring data from the central processing unit to memory is its usual use.

- Data bus: The data bus of an 8051 microcontroller has eight bits. Transferring data from one peripheral place to another is often the usage for it.