



# Lab 1: Instrumentation

**XMUT204 Electronic Design**

# Topics

## **Objectives:**

- Familiarise with the equipment and materials used for electronic laboratory.
- Measure current and voltage.
- Investigate limitations and constraints of instrumentation.
- Analyse voltage divider circuit.
- Measure resistance in device and circuits.

# The Electronics Work Station and Equipment

- In XMUT204 course and other related courses in VUW-XMUT programme, your workstation in the lab will contain the following instruments:
  - a. A GW Instek GOS-6021 analogue oscilloscope
  - b. A Rigol DG1022 waveform generator
  - c. A GW Instek GPD-3303 dual power supply
  - d. A Victor vc9801A+ digital multimeter
  - e. A As2294D AC dual channel millivolt meter
- All these instruments require a basic knowledge of their operation if we want to effectively use them in our laboratories and we gradually get familiar with the operation of each.
- In this lab, we will concentrate on the use of the DC power supply and multimeter in measuring DC voltage and current as well as resistance measurements.

# Resistor Values and Measurements

- The value of the resistor is normally provided by a four or five band colour scheme on the body of the resistor.
- Shown below is a resistor with a four-band colour scheme, where the first two bands indicate the first two digits in the resistance value and the third band indicate the multiplier.
- See in the sketch below how the colour of the band indicate the numeric value.

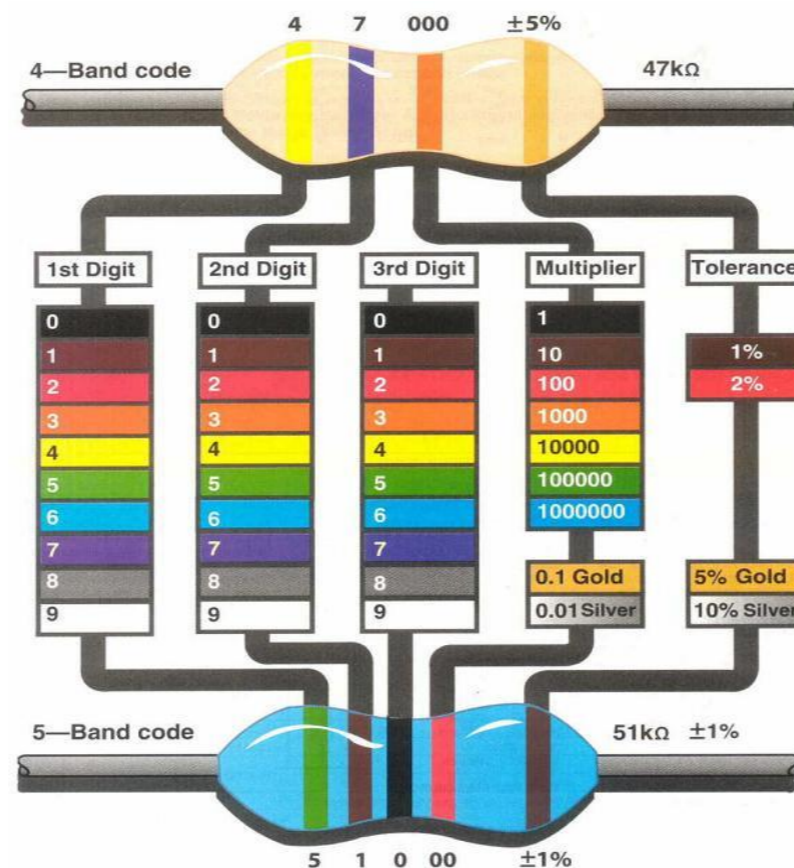

Resistor values as based on colour codes

# Resistor Values and Measurements

- Every decade of resistor values (0.1 to 1  $\Omega$ , 1 to 10  $\Omega$ , 10 to 100  $\Omega$ , ...) should contain 12 resistor values.
- For example, the decade from 1 k $\Omega$  to 10 k $\Omega$  should contain the following resistor values: 1.0 k $\Omega$ , 1.2 k $\Omega$ , 1.5 k $\Omega$ , 1.8 k $\Omega$ , 2.2 k $\Omega$ , 2.7 k $\Omega$ , 3.3 k $\Omega$ , 3.9 k $\Omega$ , 4.7 k $\Omega$ , 5.6 k $\Omega$ , 6.8 k $\Omega$ , 8.2 k $\Omega$ , this follows by 10 k $\Omega$  which will be the first resistor in the next decade.

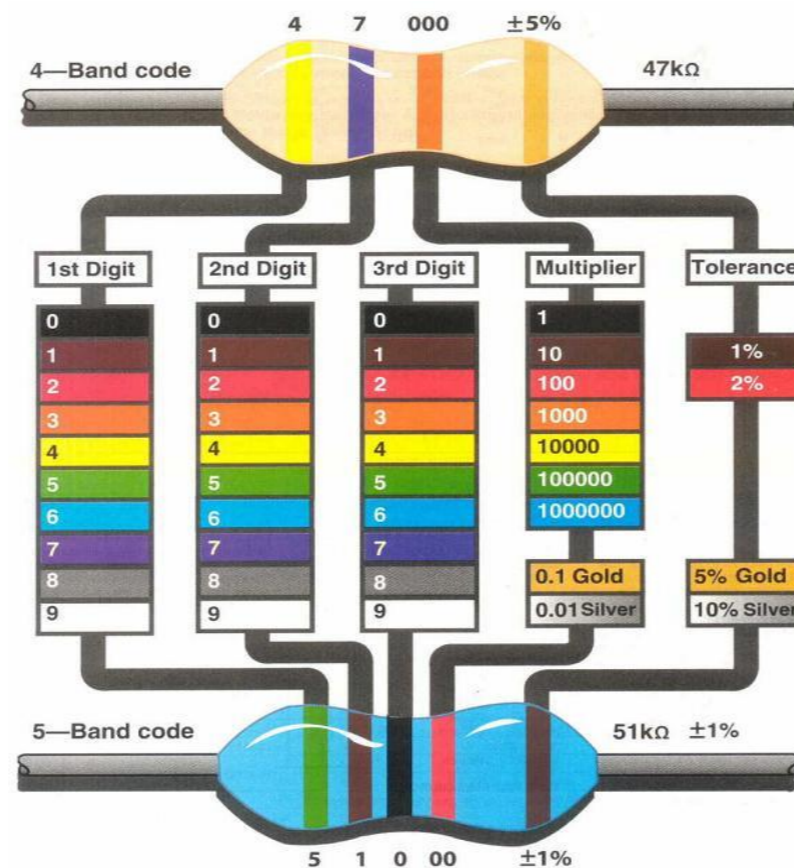

Resistor values as based on colour codes

# Continuity Measurement with the DMM

- One function of the DMM that is not so obvious, but is extremely useful, is the use as a continuity indicator.
- In this function, it emits an audible signal when a low resistance path is encountered and is ideal for fault finding on a circuit board, as the signal can be used to find open circuit connections on the board.
- Set one of your DMMs to the continuity function and use leads with crocodile clips and short pieces of hook up wire to probe the connection on the breadboard.
- Sketch the basic breadboard connection patterns and use your continuity test results to indicate the internal connections of the breadboard.

# Current and Voltage Measurements

- For the circuit below, calculate the expected values of the currents ( $I_1$  to  $I_3$ ) and the voltages over the resistors ( $V_1$  to  $V_3$ ) that will be observed in the circuit.
- Also, calculate the power dissipation in each of the resistors to check that we are within the 0.25 W limit of the resistors.

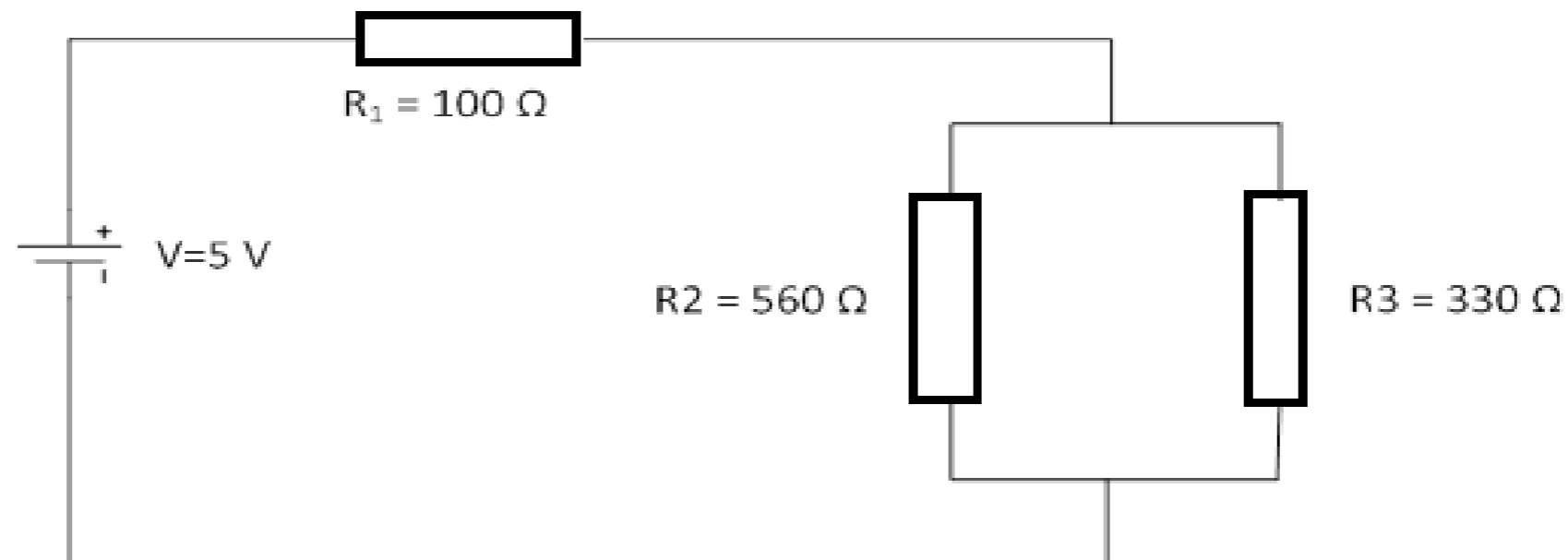

Basic circuit for section B2

# Current and Voltage Measurements

- a. Decide how you should employ your two multimeters as part of the circuit in order to perform the required measurements.

Sketch the circuit showing the multimeters and show your circuit diagram to the lab demonstrator.

Construct the actual circuit on your breadboard, double check all connections and power up the circuit from one channel of your bench power supply.

Perform the required current and voltage measurements and tabulate your results.

- b. How does the expected values of currents and voltages calculated in (a) compare to those observed in (b).

Can you explain any observed difference?



# Internal Resistance of Ammeter and Voltmeter

- One of the reasons for deviations from the expected values in B1 above may be due to our measurement instruments not meeting the required conditions for use as an ammeter (resistance  $\sim 0 \Omega$ ) or as a voltmeter (resistance  $\sim \infty \Omega$ ).
- We would like to obtain an estimate of how any non-ideal values of the meters will influence our measurements and we would also like to check what these values really are.

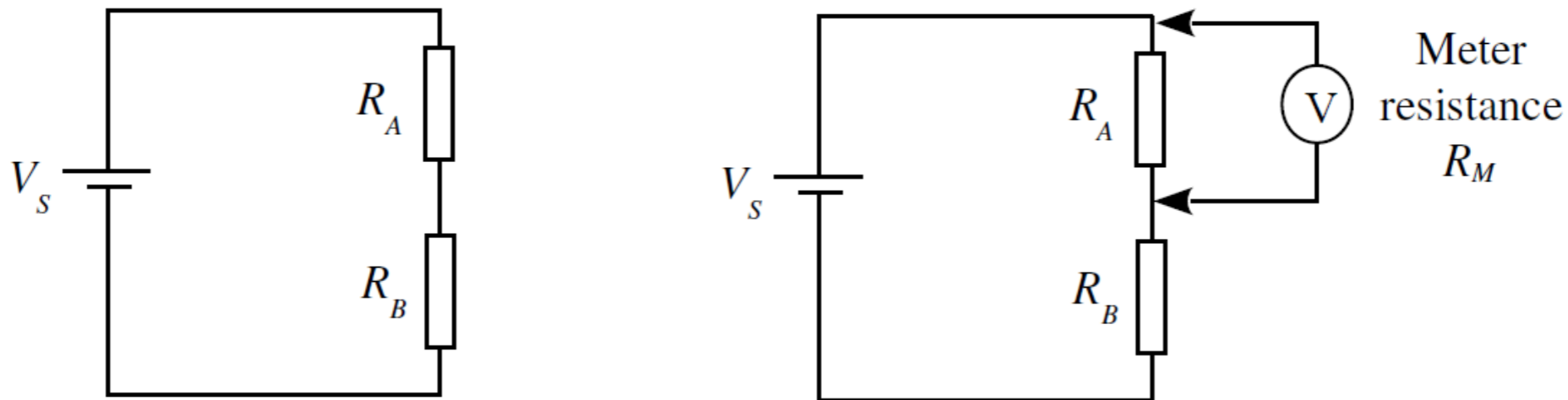

Circuits for Section B2: (a) Resistor in series (b) Resistor in series with meter

# Internal Resistance of Ammeter and Voltmeter

- a. Assume that we have a simple circuit with resistors  $R_A$  and  $R_B$  in series as shown below and you want to measure the voltage drop across  $R_B$ .

Work out expressions for what you would expect the voltages across  $R_A$  and  $R_B$  to be for the circuit in Fig. 3(a). If  $V_S = 3\text{V}$  what would the voltages across  $R_A$  and  $R_B$  be for the cases of:

- i.*  $R_A = 1\text{ k}\Omega$ ,  $R_B = 10\text{ k}\Omega$ ;
- ii.*  $R_A = 100\text{ k}\Omega$ ,  $R_B = 1\text{ M}\Omega$ ?

- b. Now, suppose that you measure these voltages using a voltmeter which has a resistance  $R_M$  associated with it as shown in Fig. 3(b).

Work out an expression for the actual voltage which would be measured across  $R_A$  and  $R_B$  using this meter. (Hint: first work out the resistance of the parallel combination of  $R_A$  (or  $R_B$ ) and the meter in parallel, and then the resulting current in the circuit.)

# Internal Resistance of Ammeter and Voltmeter

- a. What voltages would you expect across  $R_A$  and  $R_B$  to be for the circuit in Fig. 3 (for both cases (i)  $R_A = 1 \text{ k}\Omega$ ,  $R_B = 10 \text{ k}\Omega$ ; (ii)  $R_A = 100 \text{ k}\Omega$ ,  $R_B = 1 \text{ M}\Omega$ ) if the measurement is done with a voltmeter of an internal resistance of:
- i.*  $R_M = 10 \text{ k}\Omega$ ,
  - ii.*  $R_M = 1 \text{ M}\Omega$ , and
  - iii.*  $R_M = 10 \text{ M}\Omega$ ?
- b. How does the accuracy of the measurements depend upon the relationship between  $R_M$  and  $R_A$  and  $R_B$ ?
- What value of  $R_M$  is necessary for the measured voltage to be accurate?
- Explain the influence of  $R_M$  in obtaining accurate measurements. (This effect is called meter loading).

# Voltage Divider Circuits

The circuit in Figure 4 below acts as a voltage divider and divides the applied voltage from the power supply according to the resistance ratio between the two resistors:

- Write an expression for the voltage that will be observed over  $R_2$  in terms of  $R_1$ ,  $R_2$  and the supply voltage  $V_S$ .
- Now, design a voltage divider of the following form:

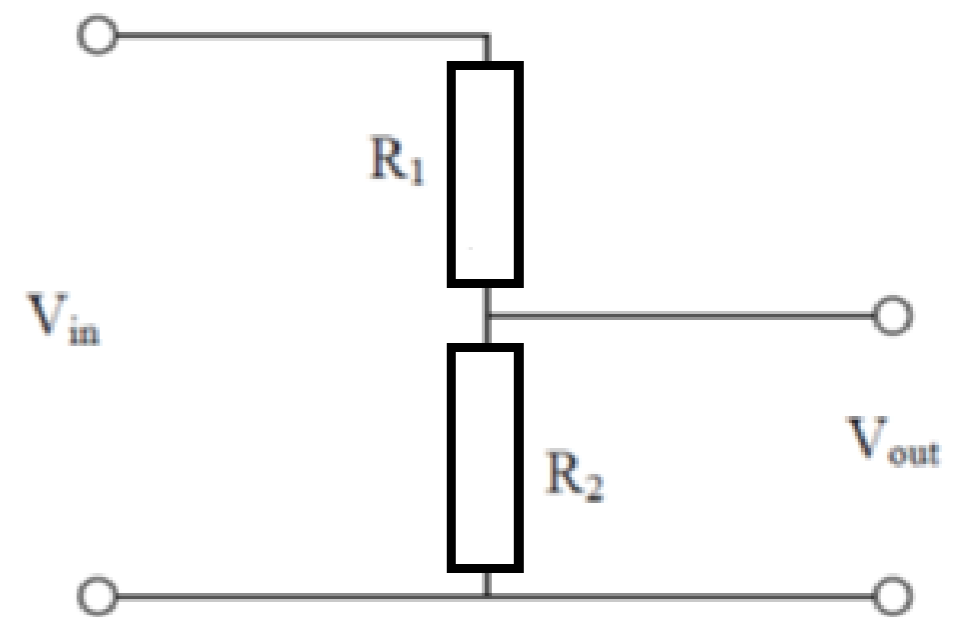

A simple voltage divider

**Design:** You should choose the values of  $R_1$  and  $R_2$  so that  $R_1 + R_2$  is equal to  $5 \text{ k}\Omega$  ( $\pm 10\%$ ) and  $V_{out} = 0.33 V_S$  ( $\pm 10\%$ ).

You may use combinations of resistors to form  $R_1$  and  $R_2$  in order to achieve these objectives.

# Voltage Divider Circuits

- a. Test your voltage divider for values of  $V_S = 1, 2, 3, 4, 5$  V and each time measure the value of  $V_{out}$  and express as a percentage of  $V_S$ .
- b. We are sometimes tempted to use this output voltage as a “stable” input voltage into the next stage of a circuit – often with disastrous result.
- c. Simulate the next stage of the circuit by adding a load resistor  $R_L$  over  $V_{out}$ . Keep  $V_S$  constant at 3 V and use different values of  $R_L$  (100  $\Omega$ , 500  $\Omega$ , 1 k $\Omega$ , 5 k $\Omega$ , 10 k $\Omega$  and for each value of  $R_L$  measure the value of  $V_{out}$  and show in a table. How stable is the value of  $V_{out} = 0.33 V_S$  (required) when adding different load resistance? Explain.
- d. Advanced design: Can you design a variable -5 V to +5 V supply by using two 9 V batteries as well as a 1 k $\Omega$  potentiometer and other resistors. Sketch your circuit design and show this to the lab demonstrator.

# Resistance Measurement with DMM

## a. Resistor Measurements

- Use your DMM to measure the resistance of a range of resistors from  $\sim 1 \Omega$  to  $1 \text{ M}\Omega$  (do one resistor from each decade) and compare the observed value to the value expected from the colour band.
- Express the difference as a % and check if it is within the expected tolerance of the resistor.

## b. Circuit Measurement

- For this section refer to the circuits given in Figure 5 and Figure 6, measure the voltage across each resistor in the circuit and also the current that flows in each resistor.

# Resistance Measurement with DMM

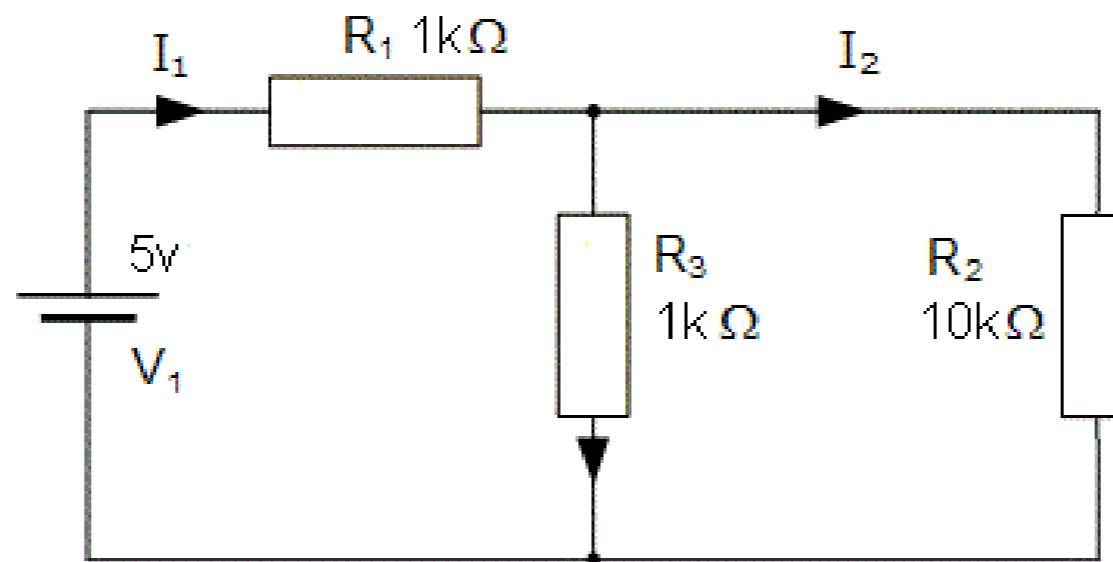

Circuit 1: Series-parallel resistors with single voltage source.

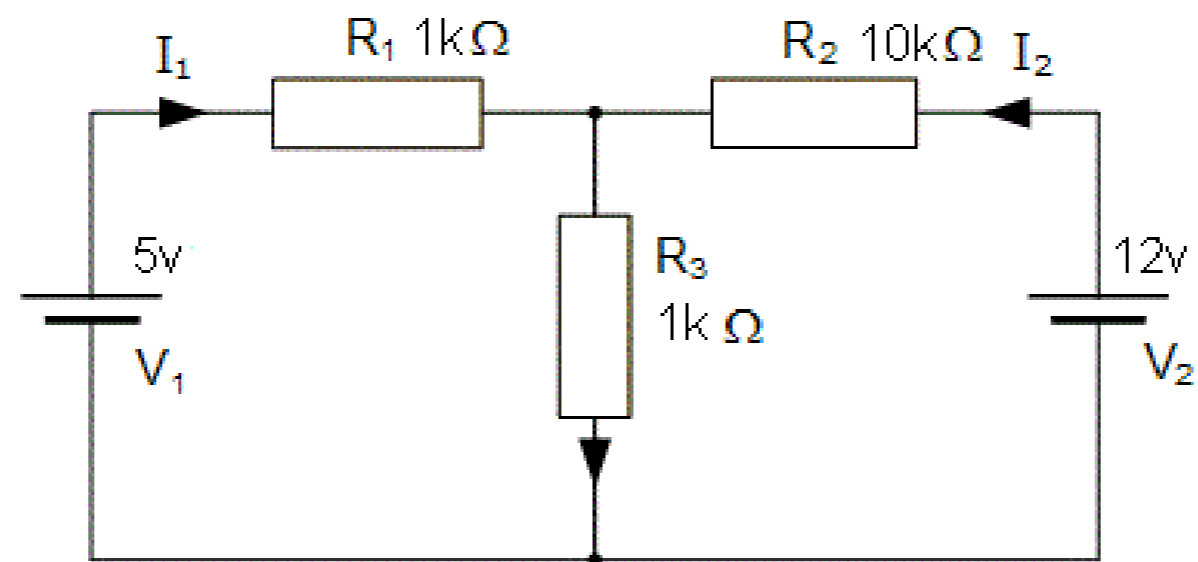

Circuit 2: Series-parallel resistors with two voltage sources.

# Report

## **Part C: Report**

- Complete a short report by answering the questions from the associated question sheet.

## **Equipment**

- Resistor:  $100\Omega$ ,  $330\Omega$ ,  $500\Omega$ ,  $560\Omega$ ,  $1\text{k}\Omega$ ,  $5\text{k}\Omega$ ,  $10\text{k}\Omega$ ,  $100\text{k}\Omega$ , and  $1\text{M}\Omega$