

Due date: Monday, 29th June 2026 (online submission to XMUT204 website at VUW)

A. BJT Amplifier Design

1. For the BJT amplifier circuit in Figure 1 below, the DC gain (β_{DC}) of the silicon BJT is 150.

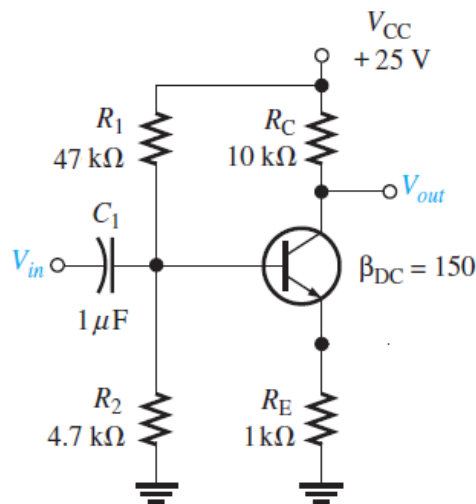

Figure 1: BJT amplifier circuit with voltage divider biasing circuit

- Derive the equation for and calculate the Q-point of the amplifier e.g. I_C and V_{CE} . [10 marks]
 - The maximum and minimum output voltage (V_{out}) if a 50 mV (rms) signal is applied at the input (V_{in}). [10 marks]
2. For a BJT amplifier circuit shown in Figure 2 below, C_3 is a bypass capacitor at the emitter. Knowing that $\beta_{DC} = \beta_{AC} = 100$, perform the DC and AC analysis of the amplifier circuit.
- The DC operating point of the amplifier circuit e.g. all relevant voltages (V_B, V_C , and V_E) and currents (I_B, I_C , and I_E) in the circuit. [10 marks]
 - Derive the equation for and calculate the voltage gain without a bypass capacitor ($A_{v(\text{without})}$). [5 marks]

- c. Derive the equation for and calculate the voltage gain with a bypass capacitor ($A_{v(\text{with})}$). [5 marks]
- d. Describe briefly which resistors influence the voltage gain of the amplifier. [5 marks]

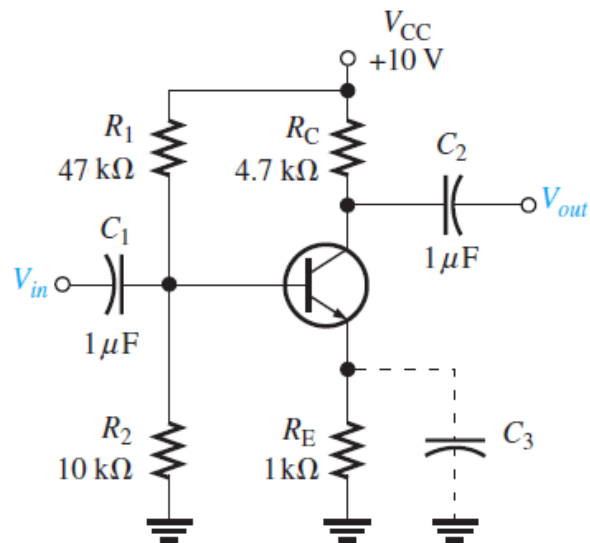

Figure 2: BJT amplifier circuit with and without feedback emitter capacitor

B. BJT Amplifier Frequency Response

3. For the BJT amplifier circuit given in the Figure 3 below, input voltage $V_{in} = 10 \text{ mV rms}$ and AC and DC gains of BJT are $\beta_{DC} = \beta_{AC} = 100$. Calculate as follows:

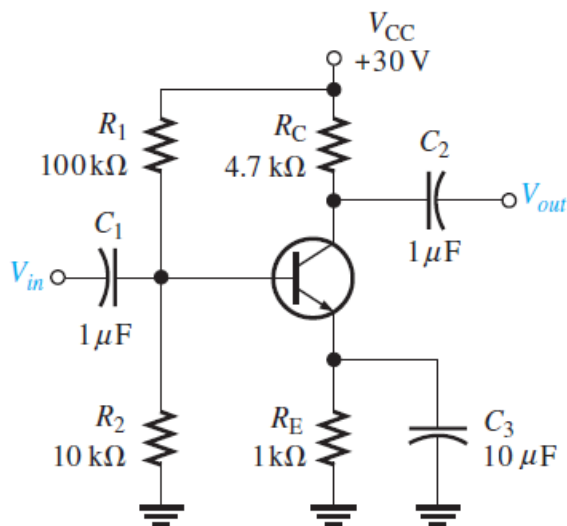

Figure 3: BJT amplifier circuit with bypass emitter capacitor

- a. The voltage gain (A_v), the current gain (A_i) and the power gain (A_p in dB) of the amplifier. [25 marks]

- b. The lower cut-off frequencies in the frequency response. [15 marks]
- c. The upper cut-off frequencies in the frequency response if $C_{ib} = C_{be} = 25 \text{ pF}$ and $C_{ob} = C_{bc} = 8 \text{ pF}$. Describe how parasitic capacitances in the circuit affect the upper frequency response of the amplifier. [15 marks]

Marking Schedule

Student ID : _____

Student Name : _____

No	Description	Mark	Your Mark	Remarks
A	BJT Amplifier Design			
1a	DC operating voltage (e.g. all relevant voltages and currents in the amplifier circuit).	10		
1b	The output voltage if a 50 mV rms signal is applied at the input.	10		
2a	The DC operating point.	10		
2b	The voltage gain without a bypass capacitor.	5		
2c	The voltage gain with a bypass capacitor.	5		
2d	Description on which resistors influence the voltage gain of the amplifier.	5		
B	BJT Amplifier Frequency Response			
3a	The voltage gain, the current gain, and the power gain (in dB) of the amplifier.	25		
3b	The lower cut-off frequencies of the frequency response.	15		
3c	The upper cut-off frequencies of the frequency response. Description of how parasitic capacitances affect the upper frequency response of the amplifier.	15		
	Total	100		

Comment: