



VICTORIA UNIVERSITY OF
WELLINGTON
TE HERENGA WAKA
NEW ZEALAND

Demo 5.2 – BJT Testing Simulation in LTspice

XMUT204 Electronic Design

Overview

- Testing of a BJT characteristics.
- Creating schematic.
- Simulation of circuit.
- Plotting the graphs.

Learning Characteristics & Operation of BJT Transistor

- Understanding the characteristics and operations of the bipolar junction transistor (BJT) is difficult and taking some time to master.
- Simulation and experimentation with the device can make it easier for you to learn.
- As a result this exercise will be about setting up a circuit for testing the BJT transistor and to obtain the properties and characteristics for NPN transistors from simulation in LTspice.
- This works with PNP too, but circuit setup is different.
- Three group of properties and characteristics are covered in this exercise e.g. current-to-voltage characteristics of the BJT transistor and DC and AC gains of the BJT amplifier.
- The transistor to be used for the exercise is 2N3904 BJT transistor which is also available in the library of LTspice software.

Testing of BJT Characteristics

- Here is a general look at how this characteristic of the BJT (I_C vs V_{CE}/V_{CC}) is visualized.

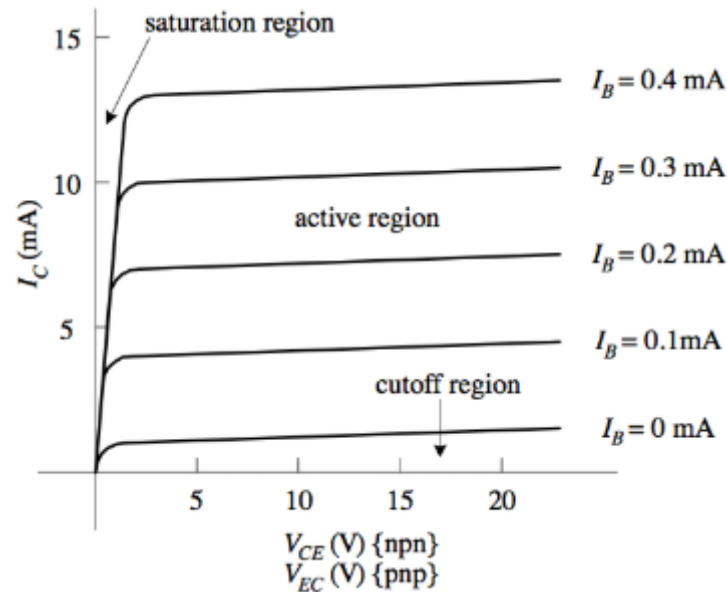

- Generally, 10 μ A steps are used to visualize how the output current (I_C) is amplified. The output is typically measured in a range of milliamps.
- These characteristics typically change (although follow the same pattern) based on several values based on the transistor's leg names: collector, emitter, and base measurements (voltage and/or current).

Testing of BJT Characteristics

- Also, a contributing factor is the current gain called Beta (β). There is another factor called Alpha (α), but can be also calculated from Beta.

$$\beta = I_c/I_b$$

- Conversely, Alpha can be calculated from (and also can be calculated from the beta by knowing $I_e = I_c + I_b$):

$$\alpha = I_c/I_e = \beta/1+\beta$$

- Beta values are typically listed in the datasheet of bipolar transistors. The values above are important to circuit designs with transistors involved.

Creating Schematic

- For obtaining the characteristics graph of the BJT transistor, a biasing circuit needs to be constructed as shown in the following diagram.
- The circuit shows a common emitter biasing configuration of the BJT transistor.

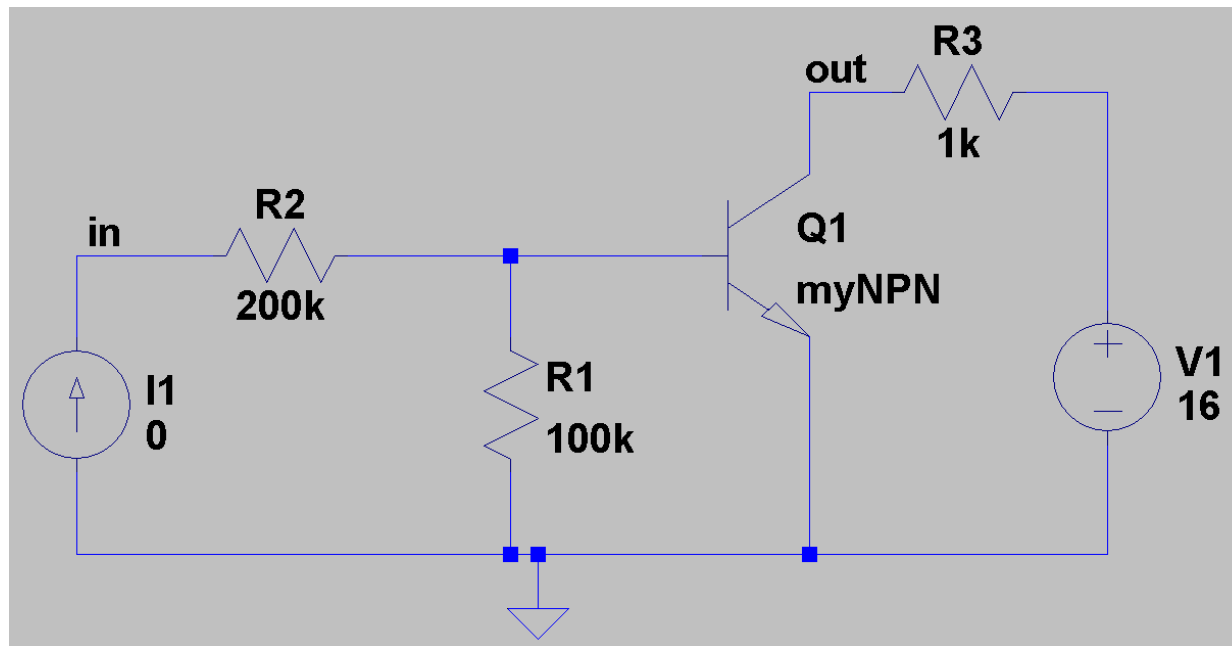

Creating Schematic

- First, add the resistors (i.e. R1, R2 and R3), voltage source (V1) and ground as shown in the circuit above and place them to the schematics in LTspice.
- Configure the devices, so $R1 = 100\text{k } \Omega$, $R2 = 200\text{k } \Omega$ and $R3 = 1\text{k } \Omega$. Set the voltage source V1 to be 16 V.
- Wire these devices in the schematic so they are connected with one to another.

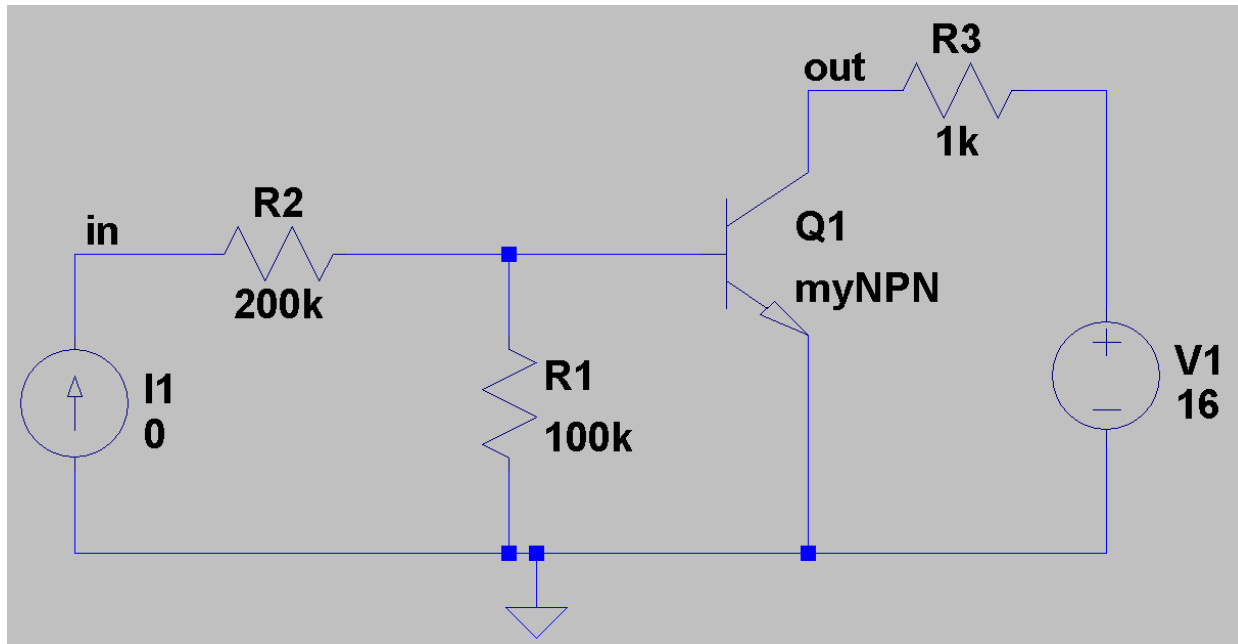

Creating Schematic

- There are two other parts that should be also added into the schematic: the current source I1 and transistor Q1 (i.e. this transistor is based on a modified 2N3904 BJT transistor model in LTspice).

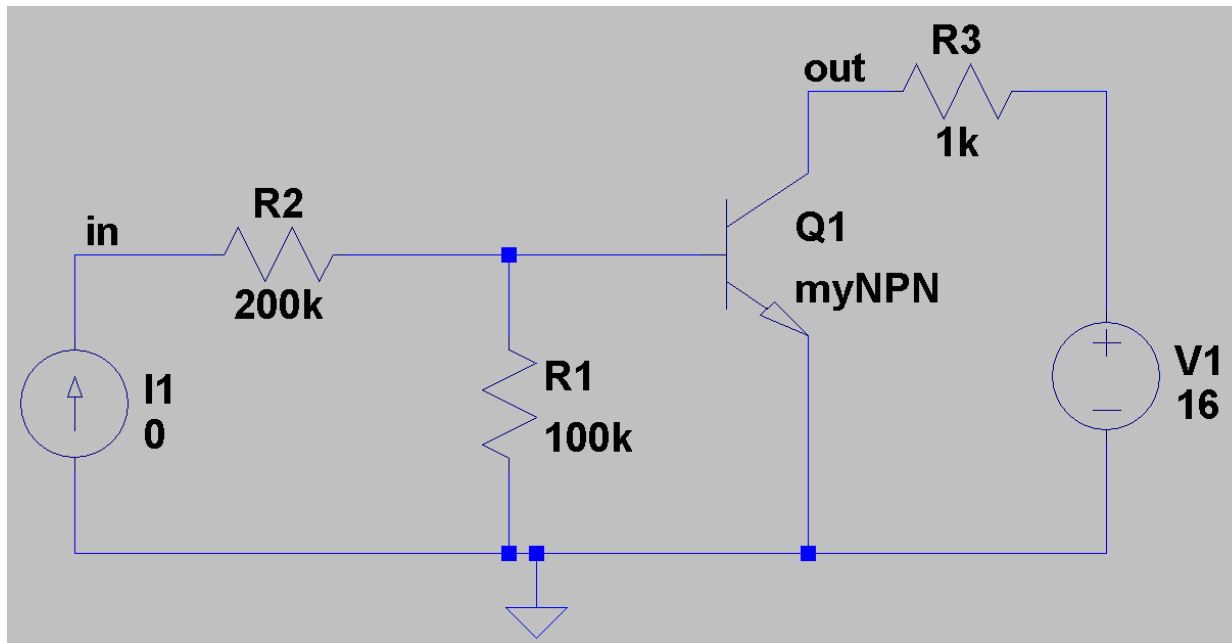
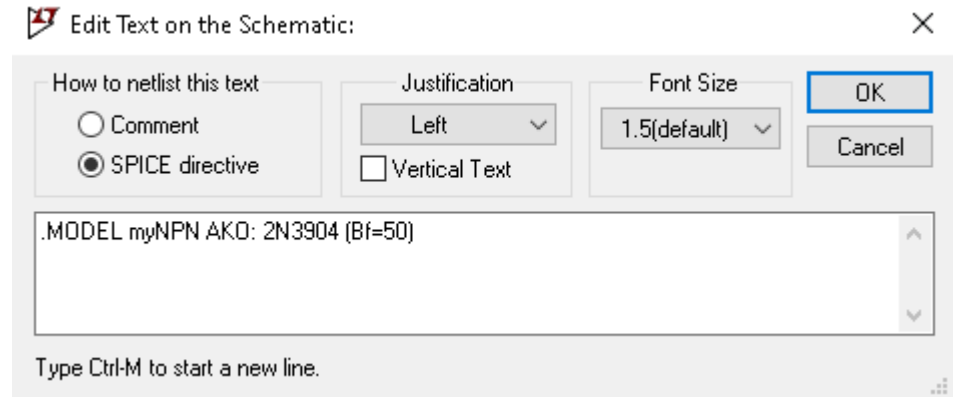

Simulation of Circuit

- To obtain the same output characteristic (I_c vs. V_{in}) on the virtual oscilloscope of LTspice, a stepped/ incremental values of devices simulation must be used i.e. a DC sweep simulation in LTspice.
- The DC Sweep will be used to sweep both of our sources: the input voltage V1 and the input current source I1.

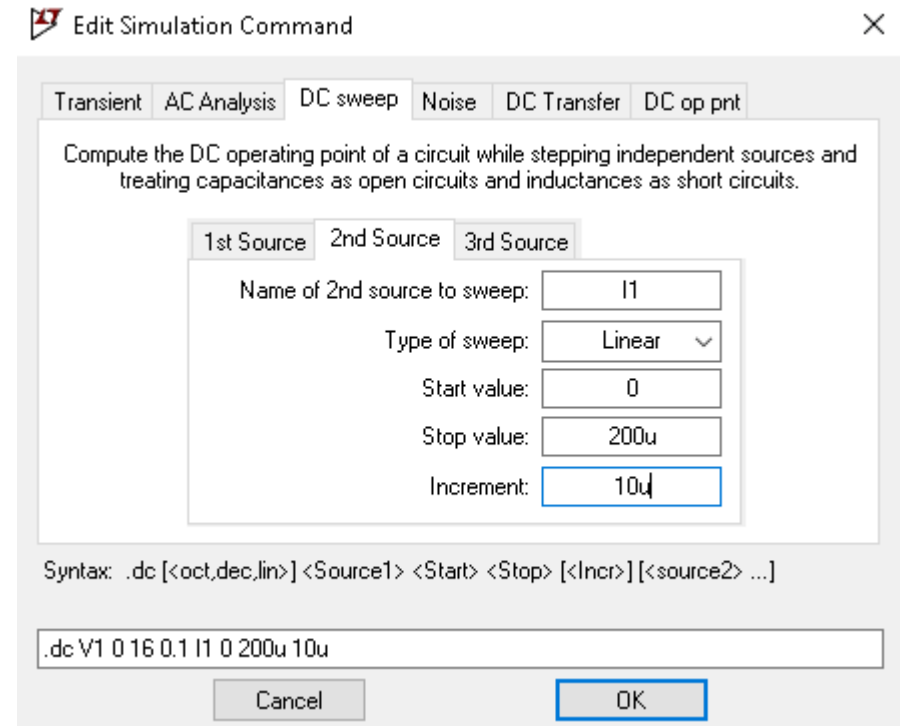
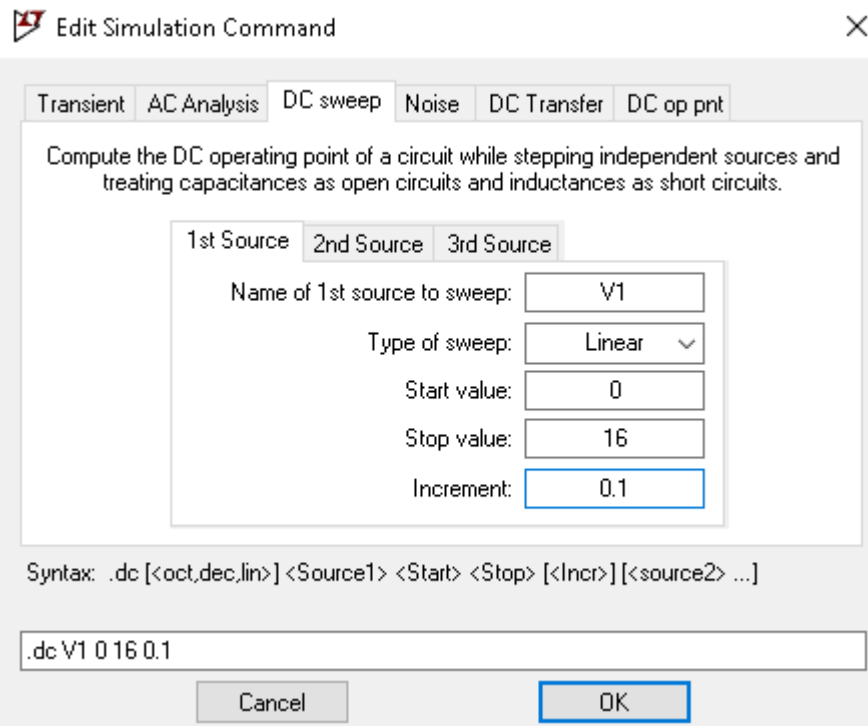

Simulation of Circuit

- The final schematic of the circuit in LTspice before plotting of the graphs.

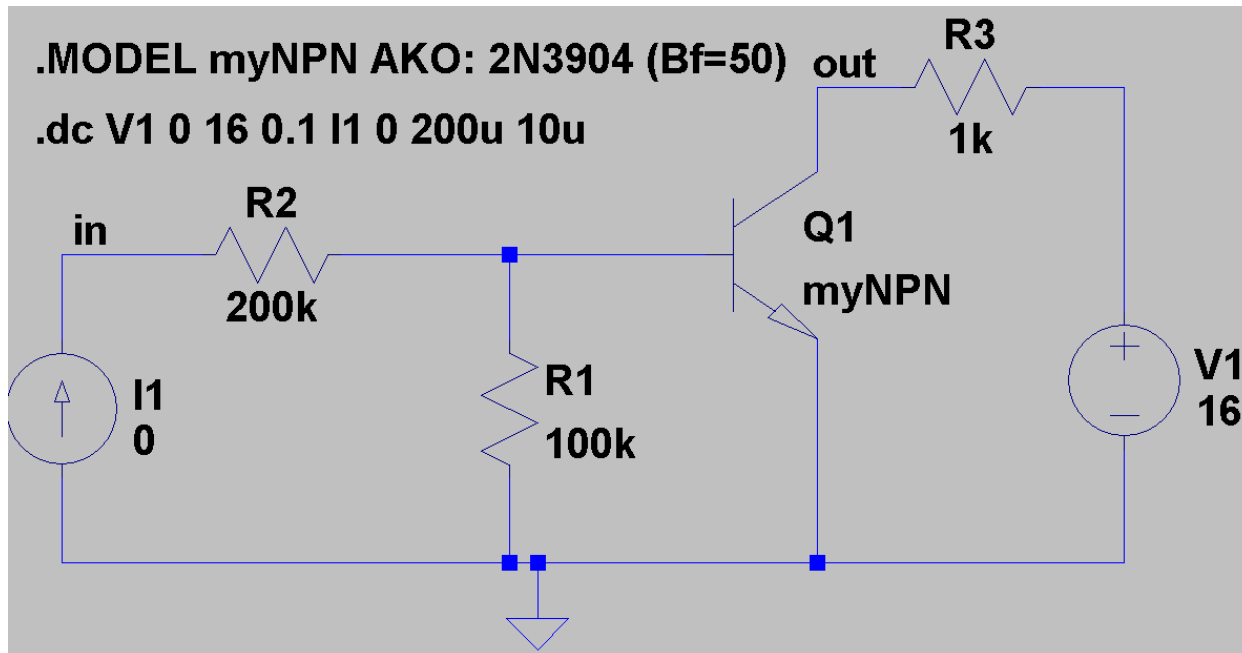

Plotting the Graphs

- Specifically for getting the same graph as mentioned before, probe the current on the leg where the $1k\Omega$ line goes into the transistor (the collector).
- A special symbol (i.e. a magnifying glass symbol) will show up if one hovers over the leg.
- Here is the voltage to current characteristics graph that we get with a Beta factor of 50 on a 2N3904 transistor with the default setup.

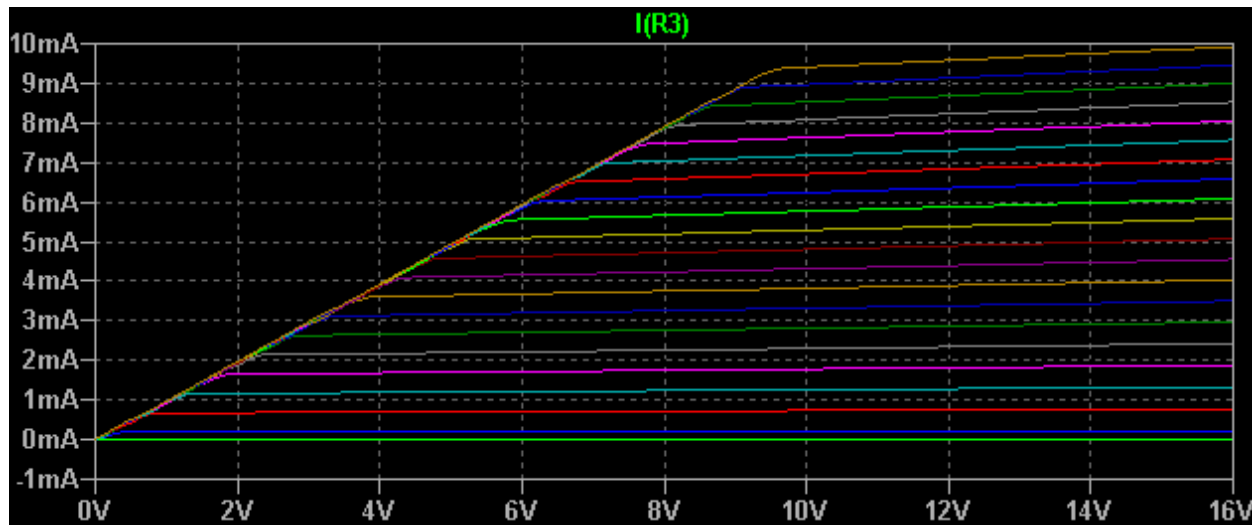

Plotting the Graphs

- The plot of the Beta of the BJT transistor that will be seen is as shown in the figure below.
- Use the equation in the Add Trace feature of LTspice: $I_c(Q1)/I_b(Q1)$ to plot Beta.

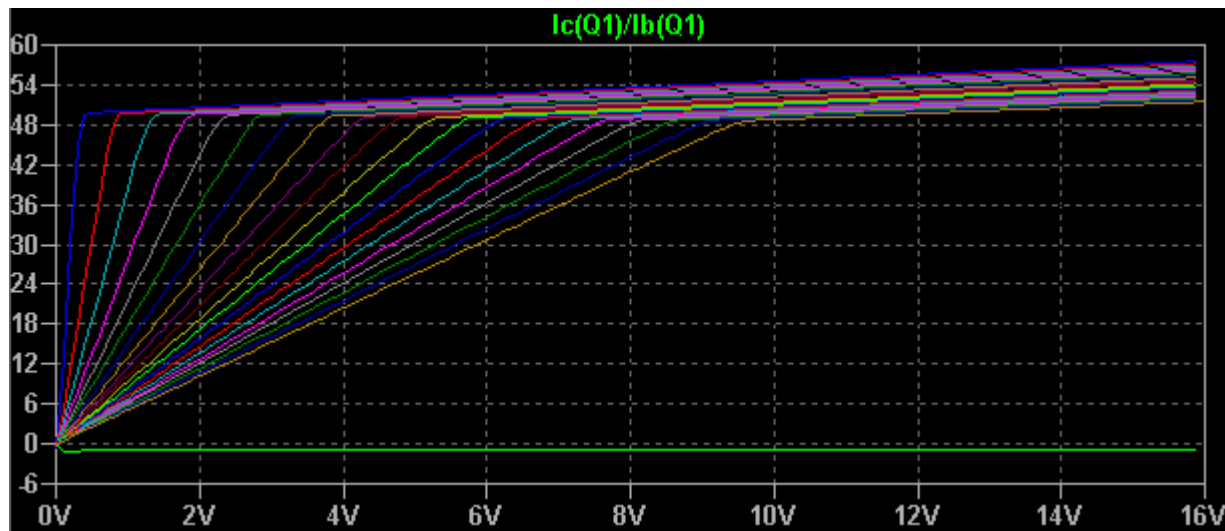
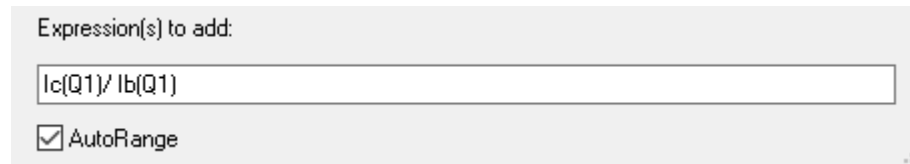

Plotting the Graphs

- To plot Alpha of the BJT transistor, we will do the same process as before,
- Use $I_c(Q1)/-I_e(Q1)$ to plot Alpha [negative I_e as I_e is the opposite of I_c to get positive values]

