



Lab 4 – BJT Properties

XMUT204 Electronic Design

Topics

Objectives:

- Introduce the two-diode model of an NPN bipolar junction transistor (BJT) and to investigate the transistor's current gain and transconductance.
- Investigate the current – voltage characteristics of a BJT in a common-emitter configuration.
- Study the voltage input-output characteristics.

Bipolar Junction Transistor

- This form of transistor comes in two varieties: NPN and PNP.
- The experiment will concentrate on the NPN transistor (specifically a BC548).
- The PNP type is similar and usually a simple reversal of voltage polarities from the NPN circuit configurations will suffice to analyse its operation as an active circuit element.

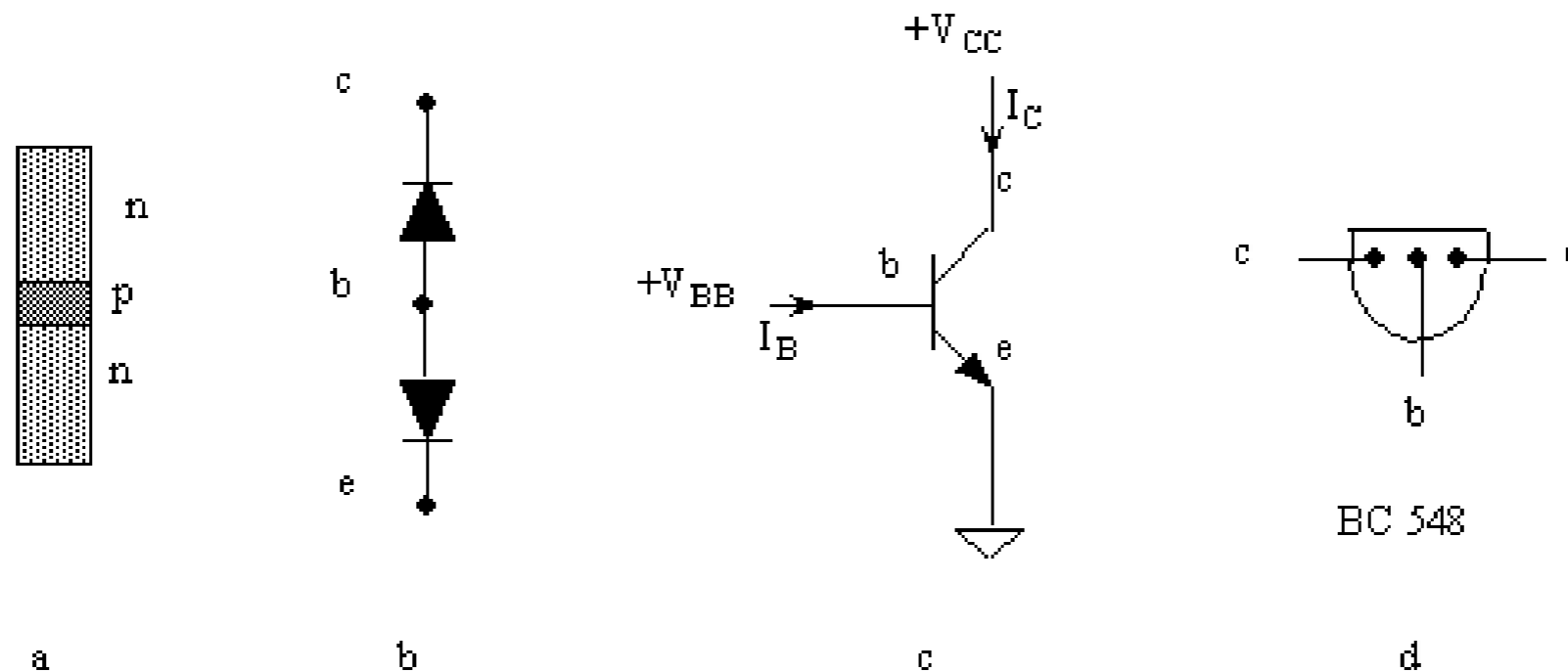

Fig. 1: BC548 transistor

Bipolar Junction Transistor

- Provided certain DC bias conditions are satisfied, a transistor is an active device that will produce a current gain (and associated power gain).
- For an NPN transistor, the collector must be more positive than the emitter and the base must be more positive than the emitter such that the be diode is forward biased and the bc diode is reverse biased.
- Under these conditions a small current into the base (here $I_B \sim 10 \mu\text{A}$) controls a much larger current in the collector-emitter circuit (here $I_C \sim \text{mA}$).

Bipolar Junction Transistor

- The relationship between I_C and I_B is shown in Fig. 2a. The dc current gain β is defined as I_C/I_B , i.e. $I_C = \beta I_B$ where β (in the range 100-500) is approximately constant.
- The small signal current gain (hfe) is $\Delta I_C/\Delta I_B$.

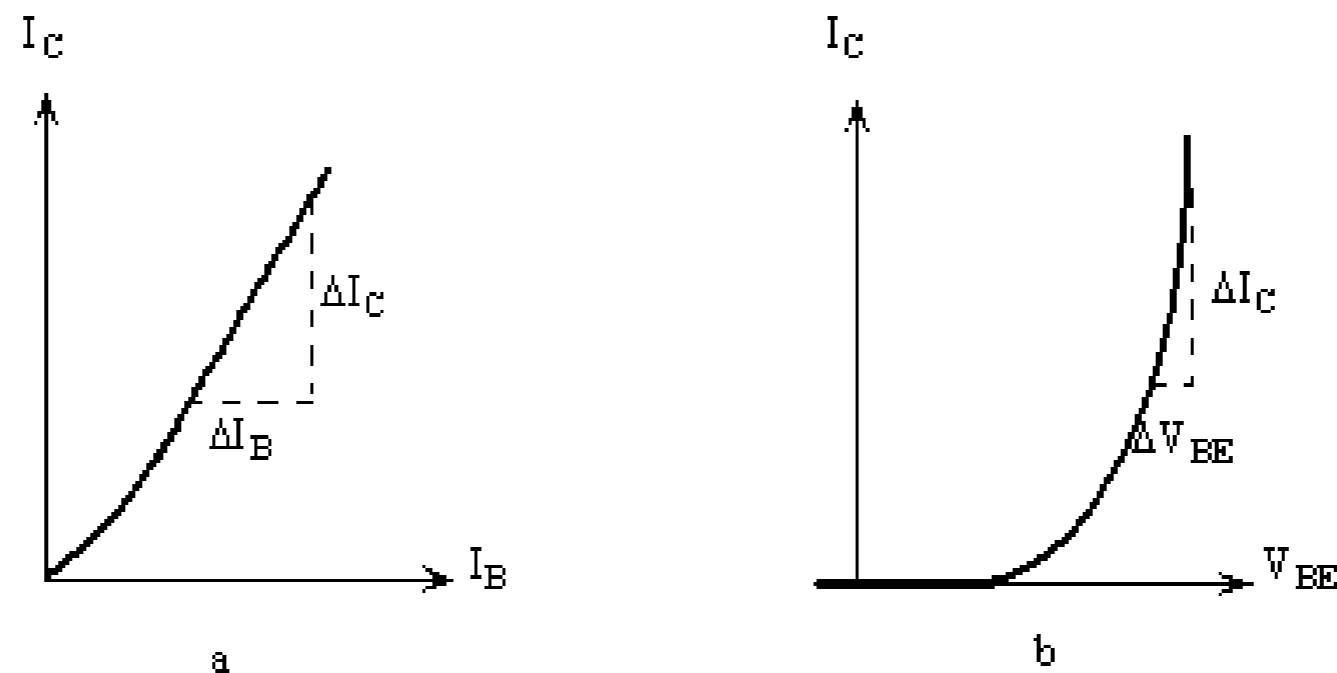

Fig. 2: I_C vs I_B and V_{BE} vs I_C graphs

- The transistor may also be considered as a transconductance amplifier.

Bipolar Junction Transistor

- The relationship between the output current I_C and V_{BE} is shown in Fig. 2b.
- Since the base-emitter junction resembles a pn diode, I_B is related to V_{BE} by the Ebers-Moll expression and since I_C is approximately linearly related to I_B (via β), then (with $n = 1$ and $I_C \gg I_S$)

$$I_C = I_S \exp \frac{V_{BE}}{V_T}$$

- The relationship between I_C and I_B is shown in Fig. 2a.
- The dc current gain β is defined as I_C/I_B , i.e. $I_C = \beta I_B$ where β (in the range 100-500) is approximately constant.
- The small signal current gain (h_{fe}) is $\Delta I_C / \Delta I_B$.

Bipolar Junction Transistor

- The slope of this curve ($\Delta I_C / \Delta V_{BE}$) represents the transconductance g_m of the device.
- As a voltage amplifier, the transistor uses appropriate resistances in the input and output circuits to convert currents to voltage differences.

Transistor junctions are diodes

1. Transistor junctions are diodes

- On a socket board, measure the resistance of the base-collector, base-emitter and collector-emitter junctions of the transistor provided.
- Use a digital multimeter on the diode setting and remember current direction is important.
- Use the two-diode model (Fig. 1b) to explain your measurements. Explain what you would expect to find for a PNP transistor.

(Note that you have to be careful with the transistor junction diodes as too much current through a diode in the forward direction can result in its destruction.)

Use of a transistor tester

2. Use of a transistor tester

- Connect your transistor to a transistor tester and obtain the value for β (h_{fe}) as given by the instrument.
- Also check that the identification of the E, B and C leads are correct as given on the mounting block.
- For the rest of the laboratory we will use the transistor in a common-emitter configuration as shown below.
- R is a decade resistance box (0Ω to $1 \text{ M}\Omega$).
- Use a multimeter to obtain the precise values of any fixed resistances you use, as this will be needed for an accurate calculation of the currents.

Use of a transistor tester

- Redraw this circuit to show all connections for your construction.
- Study the circuit and particularly the role of the current limiting resistors.
- What current is limited by each resistor and what is the limiting value of this current?
- How do you think how this may influence your measurements?

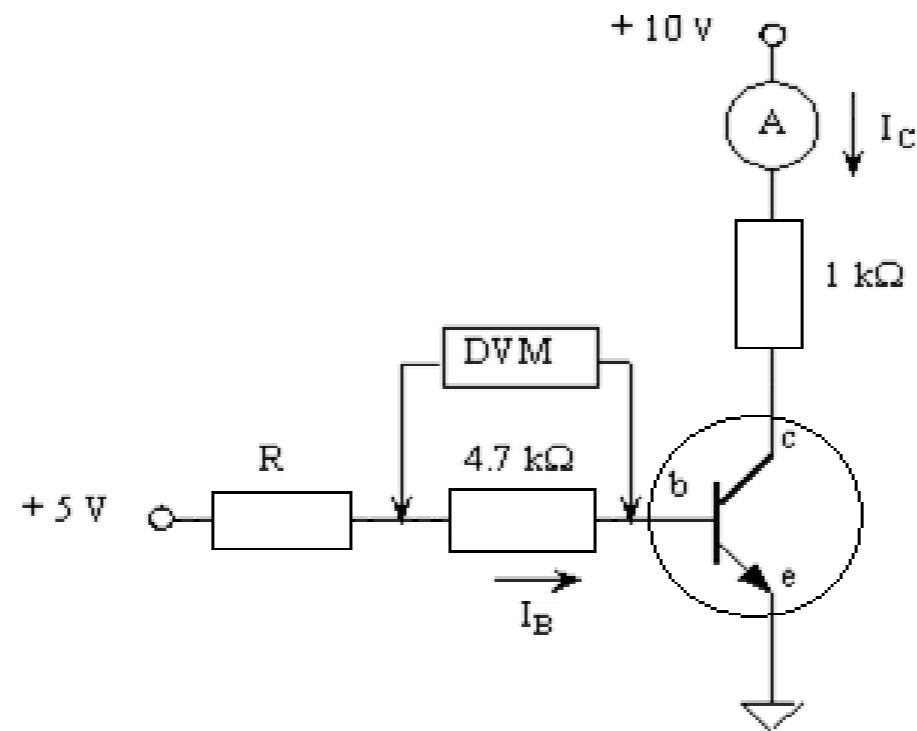

Fig. 3: Circuit for BJT DC gain measurement

Transistor as a current amplifying device

3. The transistor as a current amplifying device - β

- To measure $\beta = I_C/I_B$, set up the circuit of Fig. 3 on a socket board.
- For values of R (decade box) in the range $0 \rightarrow 1000 \text{ k}\Omega$, measure I_C , calculate I_B from the measured voltage drop across a known resistance (measure it with the DVM) and hence deduce β .
- You can start with $R = 1 \text{ M}\Omega$ and then step down in steps of $100 \text{ k}\Omega$ to $10 \text{ k}\Omega$ and then in step $10 \text{ k}\Omega$ from there.

Transistor as a transconductance device

4. The transistor as a transconductance device

- Using the same circuit (Fig. 3), but with the DVM shifted to measure V_{BE} directly.
- Vary R [and decrease the (nominal) +5 V supply as necessary] to generate collector currents in the range 0.2 \rightarrow 10 mA.
- Obtain enough measurements (~ 10) to verify the exponential increase of I_C with V_{BE} by plotting I_C against V_{BE} .

Measuring the $I_C - v_{CE}$ set of curves

5. Measuring the $I_C - v_{CE}$ set of curves

- We would now like to obtain a set of curves of different I_C vs V_{CE} values (the output parameters of the transistor) for a series of values of I_B (the input into the transistor).
- Remove the decade resistance box and sequentially set the following base currents: $I_B = 0 \mu\text{A}$, $10 \mu\text{A}$, $30 \mu\text{A}$ and $50 \mu\text{A}$ by adjusting the value of V_{BB} .
- For each of these base currents adjust the CE power supply to measure approximate values of $V_{CE} = 0.1 \text{ V}$, 0.2 V , 0.3 V , 0.4 V , 0.5 V . and the 1 V , 2 V , 3 V , 4 V and 5 V .
- Repeat for each of the base currents.

Measuring the $I_C - v_{CE}$ set of curves

- Plot the data to give the different branches of the family of I_C vs V_{CE} curves.
- Discuss how you would determine the current gain from these sets of curves.
- How does the value of β from these curves compare to that calculated earlier in the laboratory?

Output voltage as a function of input voltage

6. Output voltage as a function of input voltage

- The transistor can also be used to produce an output voltage as we will have a current flowing in the CE emitter circuit.
- Set up your circuit as below.

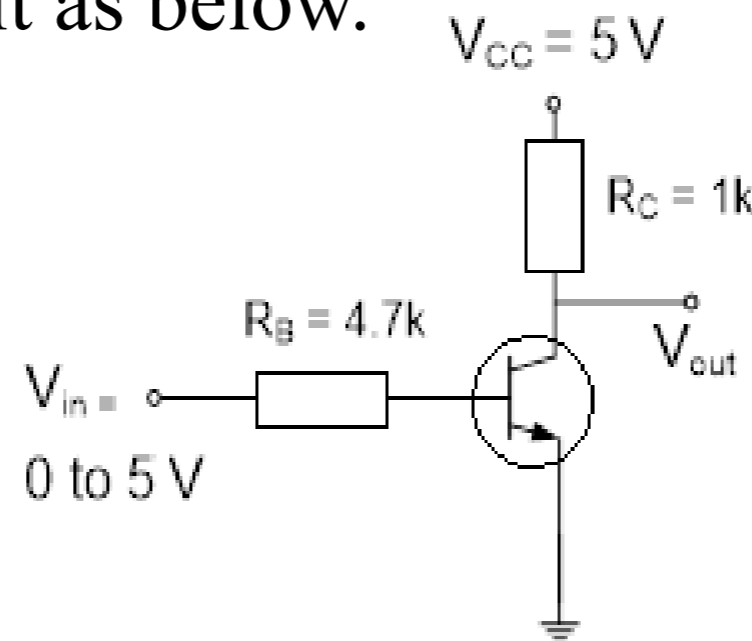

Fig. 4: BJT amplifier circuit

- Slowly vary and measure the input voltage while also recording the output voltage.
- Take more measurements when sharp changes would be observed.
- Plot V_{out} vs V_{in} and explain your observations.

Report

Part C: Report

- Complete a short report by answering questions from the associated question sheet.

Equipment

- Transistor: BC 548
- Decade resistance box
- Resistors: 470 Ω , 1 k Ω , 4.7 k Ω