

Due date: You need to submit a report to XMUT co-teacher; please contact him for how and when to submit it.

Objectives:

In laboratory 4, you measured the current – voltage characteristics of a BJT in the common emitter configuration. In this lab, we will now look at two applications of this transistor configuration:

- the use of BJTs as switches in order to construct basic digital logic gates.
- the use of a BJT as a common emitter amplifier.

In each case, we will also determine the operating point of the transistor on the current-voltage curve as measured in Lab 4. We will use resistor networks as discussed in class to provide the correct bias voltage to place it as close as possible to the correct operating point.

Part A: Theory

We will be looking at two applications of BJT transistor in this laboratory exercises e.g. switching and amplifier applications.

For the switching application, we can use the transistor as an ON – OFF switch by switching it between the cut-off region (transistor OFF and $I_C = 0$) and the saturation region (transistor ON and $I_C = \text{max}$).

For the amplifier application, BJT can be used as current and voltage amplifiers. Transistor has been viewed as a current amplifier as the collector current is much larger than the base current:

$$I_C = \beta_{DC} I_B$$

In the active region of operation, this value of β will be a constant and any increase/decrease in I_B will lead to a proportional increase/decrease in I_C . We will now look at the transistor as a voltage amplifier where the signals are small AC voltages compared to the DC bias voltages.

Part B: Experiment

The three exercises that will be performed in this lab are BJT as switch and a digital logic gate, the value of β in active region, and BJT as an amplifier.

1. The BJT as a switch and a digital logic gate

- a. Set up your circuit as shown in the figure below.

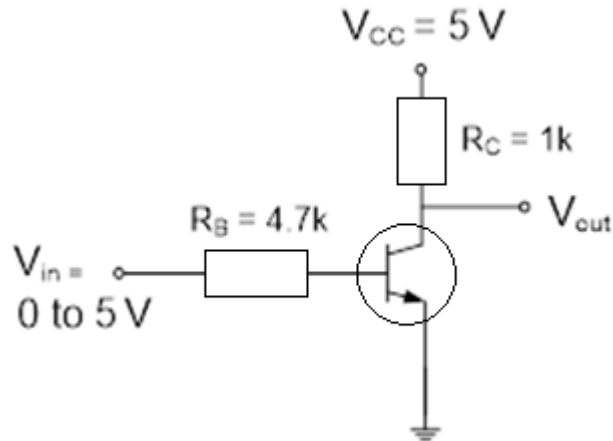

Figure 1: Using the BJT as a switch

Slowly vary and measure the input voltage while also recording the output voltage. Take more measurements when sharp changes would be observed. Plot V_{out} vs V_{in} and explain your observations.

- b. If we associate TRUE & FALSE **logic** values with HI ($\sim 4-5$ V) and LO ($0 - \sim 0.8$ V) electrical voltage **ranges**, then the results of part (a) show that this circuit may be used for the logic operation of inversion or complementation.

In	Out
LO	
HI	

What logic function does this circuit perform?

- c. If we now assume that the input voltage will either be a LO or a HI, look at your current – voltage characteristics from last week and plot the Q point for the midrange of the input = LO as well as the Q point for the midrange of the input = HI. What regions in the V-I characteristics does this represent? What will be the operating point if the input voltage is 2.5 V? Explain what will be the logic output

in this case?

2. The value of β in the active region

When using the BJT as an amplifier, we may want to use the value $\beta = I_C/I_B$ to calculate the collector current that will be produced by a selected base current. We will now use the BJT transistor in the common emitter configuration and use resistor networks (to be discussed in class) to provide the correct bias and stabilize the point of operation.

- Use your graph of current – voltage curve from Lab 4 and calculate the β value of your transistor in the active region. Do this at several points in the active region and show the values in a table:

I_B (μA)	V_{CE} (Volts)	I_C (mA)	β

Calculate the average, minimum and maximum value of β obtained. Also, obtain the β values from other students in the lab.

Measurement	B average	B maximum	B minimum
Own			
Another 1			
Another 2			
Another 3			

For the circuit below as shown in Figure 2, use the minimum and maximum values of β in the table above and calculate the operating point (V_{CE} and I_C) in each case. How widely do these operating points differ?

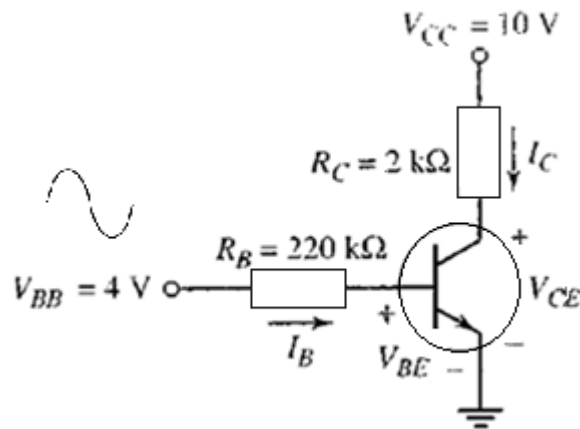

Figure 2: BJT common emitter circuit

Hopefully the above calculations is a good illustration that we should not rely on the value of β to determine the operating point, as this value can differ significantly between the same model of transistors.

In addition, β will also vary strongly with temperature. We would then rather use bias circuits (the external components such as resistors and capacitors) to ensure that we obtain a stable bias point. The use of voltage divider bias circuits such as in Figure 3 can provide this stability.

3. The BJT as an amplifier

- a. Connect the circuit of Fig. 3 using the BJT board provided. The following values apply:

R_{B1}	$50 \rightarrow 500 \text{ k}\Omega$	R_C	$0.3 \rightarrow 10 \text{ k}\Omega$	$C_1 = C_2 = 1 \mu\text{F}$
R_{B2}	$22 \text{ k}\Omega$	R_e	$1 \text{ k}\Omega$	$C_e = 10 \mu\text{F}$

- b. Setting both R_{B1} and R_C at mid range, connect a 20 mV pp, 1 kHz sine wave from the signal generator to v_i . Examine both v_i and v_o on the dual trace oscilloscope.

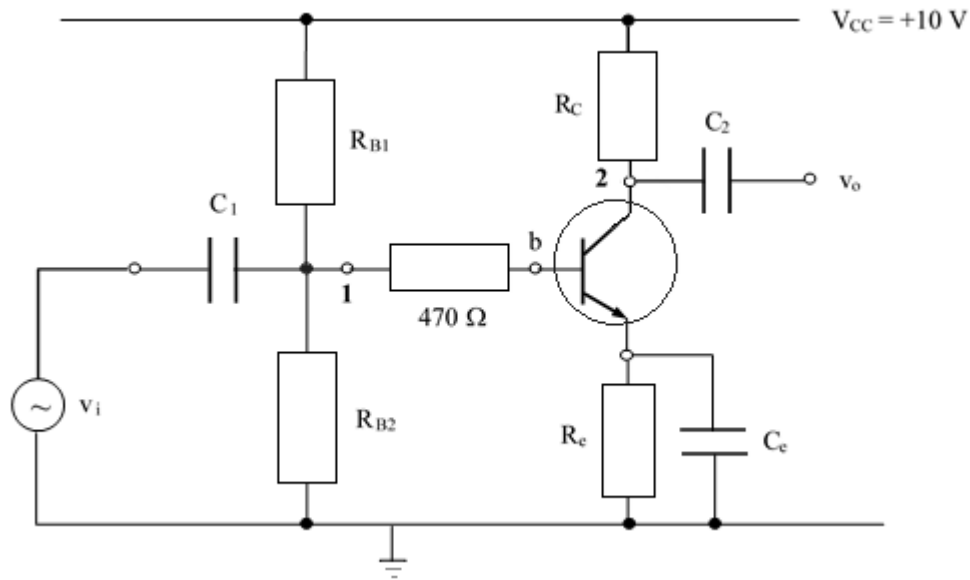

Figure 3: BJT common emitter amplifier

- c. R_{B1} and R_{B2} constitute a potential divider determining the bias (dc operating) condition of the transistor. Maintaining R_C at mid-range, set R_{B1} at maximum. Examine points 1 and 2 with the oscilloscope (set to dc coupling, both traces 2 V/cm, ground near the base of the screen). Initially $V_B \sim 0$ V, $V_C \sim 10$ V and the transistor is cut-off. Progressively decrease R_{B1} until the transistor starts to conduct (active mode). Note the changes to V_B and V_C and the output sine wave. Adjust R_{B1} to provide an undistorted sine wave output. Explain your observations.
- d. Observe v_i and v_o again on the oscilloscope and determine the voltage gain $A = v_i / v_o$. Note any phase difference. Now, remeasure A with C_e removed.
- e. Explain the operation of the circuit, including the function of the dc blocking capacitors C_1 and C_2 . (Note: you may assume that $R_C = 5.5$ k Ω). Finally reconnect C_e .
- f. Remove the ac signal part and measure I_B , V_{CE} and I_C for the DC bias only. Plot this operating point on the V_{CE} vs I_C characteristic curves from Lab 4.

Part C: Report

Now complete a short report by answering the questions from the associated question sheet.

Equipment:

Transistor: BC 548.

Resistors: 220 Ω , 470 Ω , 1 k Ω , 4.7 k Ω , 22 k Ω .

Decade resistance box.