

XMUT315 Control Systems Engineering

Tutorial 1: Laplace Transform and System Modelling (Solution)

A. Laplace Transform

1. Determine the complete response of the following model, which has a ramp input. [6 marks]

$$\frac{dx}{dt} + 3x = 5t \quad \text{and} \quad x(0) = 10$$

Solution

Applying the transform to the equation we obtain:

$$sX(s) - x(0) + 3X(s) = \frac{5}{s^2}$$

Solve for $X(s)$, the equation above becomes:

$$X(s) = \frac{x(0)}{s+3} + \frac{5}{s^2(s+3)} = \frac{10}{s+3} + \frac{5}{s^2(s+3)}$$

2. Given the following differential equation, solve for $y(t)$ if all initial conditions are zero. Use the Laplace transform.

$$\frac{d^2y}{dt^2} + 12\frac{dy}{dt} + 32y = 32u(t)$$

Also determine its inverse Laplace transform.

[12 marks]

Solution

Substitute the corresponding $F(s)$ for each term in the equation above, using standard solutions in the table, and the initial conditions of $y(t)$ and $dy(t)/dt$ given by $y(0^-) = 0$ and $y'(0^-) = 0$, respectively. Note also that $u(t)$ is any general function or signal. Hence, the Laplace transform of equation as above is:

$$s^2Y(s) + 12sY(s) + 32Y(s) = \frac{32}{s}U(s)$$

Solving for the response, $Y(s)$, yields

$$\frac{Y(s)}{U(s)} = \frac{32}{s(s^2 + 12s + 32)} = \frac{32}{s(s + 4)(s + 8)}$$

To solve for $y(t)$, we notice that the equation as above does not match any of the terms in the Laplace table. Thus, we form the partial-fraction expansion of the right-hand term and match each of the resulting terms with $F(s)$ in the table. Therefore,

$$\frac{Y(s)}{U(s)} = \frac{32}{s(s + 4)(s + 8)} = \frac{K_1}{s} + \frac{K_2}{(s + 4)} + \frac{K_3}{(s + 8)}$$

Using partial fraction of the equation:

$$K_1 = \left. \frac{32}{(s + 4)(s + 8)} \right|_{s \rightarrow 0} = 1$$

$$K_2 = \left. \frac{32}{s(s + 8)} \right|_{s \rightarrow -4} = -2$$

$$K_3 = \left. \frac{32}{s(s + 4)} \right|_{s \rightarrow -8} = 1$$

Hence

$$\frac{Y(s)}{U(s)} = \frac{1}{s} - \frac{2}{(s + 4)} + \frac{1}{(s + 8)}$$

Since each of the three component parts of equation above is represented as an $F(s)$ in the table, $y(t)$ is the sum of the inverse Laplace transforms of each term. Hence,

$$y(t) = (1 - 2e^{-4t} + e^{-8t})u(t)$$

3. Obtain the Laplace transform the following second-order differential equation as shown below. Notice the initial conditions of the equation. [10 marks]

$$\ddot{x}(t) + 4\dot{x}(t) + 53x(t) = 15u(t)$$

And

$$\dot{x}(0) = 8 \quad x(0) = -19$$

Solution

We know that the Laplace transform of the second derivative part of the equation is:

$$\ddot{x}(t) \Leftrightarrow s^2X(s) - sx(0) - \dot{x}(0)$$

The Laplace transform of the first derivative part of the equation is:

$$\dot{x}(t) \Leftrightarrow sX(s) - x(0)$$

So, applying Laplace transform to the entire equation, this gives:

$$s^2X(s) - sx(0) - \dot{x}(0) + 4[sX(s) - x(0)] + 53X(s) = \frac{15}{s}$$

Rearranging the equation above, the equation above becomes:

$$X(s)(s^2 + 4s + 53) - x(0)s - \dot{x}(0) + 4x(0) = \frac{15}{s}$$

Solve for $X(s)$ using the given initial conditions.

$$\begin{aligned} X(s) &= \frac{x(0)s + \dot{x}(0) + 4x(0)}{s^2 + 4s + 53} + \frac{15}{s(s^2 + 4s + 53)} \\ &= \frac{8s + 13}{s^2 + 4s + 53} + \frac{15}{s(s^2 + 4s + 53)} \end{aligned}$$

The first term on the right of equation above corresponds to the free response. On the other hand, the second term on the right of equation above corresponds to the forced response.

As a result, we can combine the terms on the right side of equation above into a single term as follows:

$$X(s) = \frac{x(0)s^2 + [\dot{x}(0) + 4x(0)]s + 15}{s(s^2 + 4s + 53)} = \frac{8s^2 + 13s + 15}{s[(s + 2)^2 + 7^2]}$$

4. Obtain the inverse Laplace transform of the following transfer function equation. [8 marks]

$$X(s) = \frac{5}{s(s + 3)}$$

Solution

The denominator roots are $s = 0$ and $s = -3$, which are distinct and real.

Thus, the partial-fraction expansion has the form:

$$X(s) = \frac{5}{s(s + 3)} = \frac{C_1}{s} + \frac{C_2}{s + 3}$$

Using the coefficient formula of partial fraction expansion, we obtain:

$$C_1 = \lim_{s \rightarrow 0} s \left[\frac{5}{s(s + 3)} \right] = \lim_{s \rightarrow 0} \left(\frac{5}{s + 3} \right) = \frac{5}{3}$$

And

$$C_2 = \lim_{s \rightarrow -3} \left[(s + 3) \frac{5}{s(s + 3)} \right] = \lim_{s \rightarrow -3} \left(\frac{5}{s} \right) = -\frac{5}{3}$$

The inverse transform is:

$$x(t) = C_1 + C_2 e^{-3t} = \frac{5}{3} - \frac{5}{3} e^{-3t}$$

5. Inverse Laplace transform the following transfer function equation by representing it as the sum of terms that appear in Laplace transform table. [14 marks]

$$X(s) = \frac{8s + 13}{s^2 + 4s + 53}$$

Solution

The roots of the denominator are a complex pair of $s = -2 \pm 7j$ and so the transform can be expressed as:

$$X(s) = \frac{8s + 13}{(s + 2)^2 + 49}$$

We can express $X(s)$ as a sum of terms similar to entries in Laplace transform table.

$$X(s) = \frac{s + a}{(s + a)^2 + b^2} + \frac{b}{(s + a)^2 + b^2}$$

Note that $a = 2$ and $b = 7$, so the equation above becomes:

$$\begin{aligned} X(s) &= \frac{8s + 13}{(s + 2)^2 + 49} \\ &= \frac{C_1(s + 2)}{(s + 2)^2 + 49} + \frac{C_2 7}{(s + 2)^2 + 49} \\ &= \frac{C_1(s + 2) + 7C_2}{(s + 2)^2 + 49} \end{aligned}$$

Comparing numerators, we see that:

$$\begin{aligned} 8s + 13 &= C_1(s + 2) + 7C_2 \\ &= C_1 s + 2C_1 + 7C_2 \end{aligned}$$

This is true only if $C_1 = 8$ and $2C_1 + 7C_2 = 13$, or $C_2 = -3/7$.

As a result, the equation of the system is now:

$$X(s) = \frac{C_1(s + 2)}{(s + 2)^2 + 49} + \frac{C_2 7}{(s + 2)^2 + 49}$$

Taking inverse Laplace transform, the equation above becomes:

$$x(t) = C_1 e^{-2t} \cos 7t + C_2 e^{-2t} \sin 7t$$

Substituting the coefficients C_1 and C_2 with their values, the expression for the system in the time domain is:

$$x(t) = 8e^{-2t} \cos 7t - \left(\frac{3}{7}\right) e^{-2t} \sin 7t$$

6. Given below is a transfer function $F(s)$ with real and repeated roots in the denominator.

$$F(s) = \frac{2}{(s+1)(s+2)^2}$$

Find $f(t)$ through inverse Laplace transform.

[10 marks]

Solution

Write the partial-fraction expansion of the equation as a sum of terms, where each factor of the denominator forms the denominator of each term.

In addition, each of the multiple roots generates additional terms consisting of denominator factors of reduced multiplicity.

$$F(s) = \frac{2}{(s+1)(s+2)^2} = \frac{K_1}{(s+1)} + \frac{K_2}{(s+2)^2} + \frac{K_3}{(s+2)}$$

Equate both sides to make them having the same denominator.

$$\frac{2}{(s+1)(s+2)^2} = \frac{(s+2)^2 K_1 + (s+1)K_2 + (s+1)(s+2)K_3}{(s+1)(s+2)^2}$$

With $s = -1$, then $k_1 = 2$ using procedure described in the previous question.

$$K_1 = \lim_{s \rightarrow -1} \frac{2}{(s+2)^2} = 2$$

Constant K_2 can be found by multiplying both sides of the above equation by $(s+2)^2$, resulting:

$$\frac{2}{s+1} = (s+2)^2 \frac{K_1}{(s+1)} + K_2 + (s+2)K_3$$

Letting $s \rightarrow -2$, $K_2 = -2$

To find K_3 , we differentiate the above equation with respect to s

$$\frac{-2}{(s+1)^2} = \frac{(s+2)s}{(s+1)^2} K_1 + K_3$$

By isolating K_3 , we can find it if we let $s \rightarrow -2$, hence $K_3 = -2$

$$F(s) = \frac{2}{(s+1)(s+2)^2} = \frac{2}{(s+1)} - \frac{2}{(s+2)^2} - \frac{2}{(s+2)}$$

Finally, by looking up each of the components of the above equation in the table, hence $f(t)$ is the sum of the inverse Laplace transform of each term.

$$f(t) = 2e^{-t} - 2te^{-2t} - 2e^{-2t}$$

B. Modelling of Physical Systems

7. Figure below shows a two-mass system where the displacement $y(t)$ of the right-hand end of the spring is a given function. The masses slide on a frictionless surface. When $x_1 = x_2 = y = 0$, the springs are at their free lengths. Derive the equations of motion and determine transfer function equation of the system as $X_2(s)/Y(s)$. [10 marks]

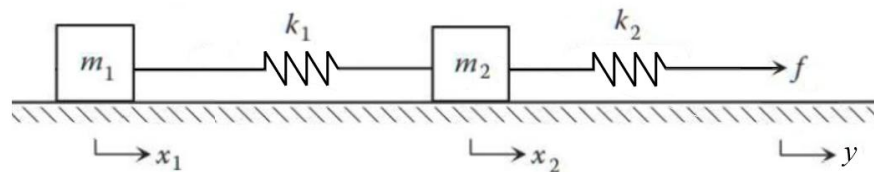

Solution

The free body diagrams shown in the figure below display only the horizontal forces, and they were drawn with the assumptions that $y > x_2 > x_1$.

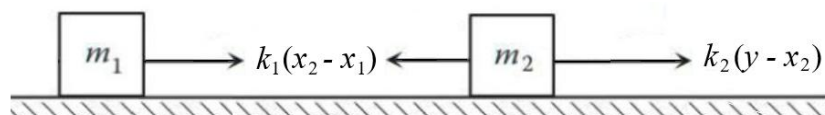

These diagrams give the equations of motion by applying Newton's second law with the direction is to the right-hand side:

$$m_1 \ddot{x}_1 = k_1(x_2 - x_1) \quad (Eq. 1)$$

And

$$m_2 \ddot{x}_2 = -k_1(x_2 - x_1) + k_2(y - x_2) \quad (Eq. 2)$$

Applying Laplace transform, the equations above become:

$$m_1 s^2 X_1(s) = k_1[X_2(s) - X_1(s)] \quad (Eq. 3)$$

Thus

$$X_1(s) = \frac{k_1 X_2(s)}{m_1 s^2 + 1} \quad (Eq. 4)$$

And

$$m_2 s^2 X_2(s) = -k_1 [X_2(s) - X_1(s)] + k_2 [Y(s) - X_2(s)] \quad (\text{Eq. 5})$$

Substituting variable X_1 in equation (5) with equation (4), the transfer function equation for the system is:

$$m_2 s^2 X_2(s) = -k_1 \left[X_2(s) - \frac{k_1 X_2(s)}{m_1 s^2 + 1} \right] + k_2 [Y(s) - X_2(s)]$$

Thus

$$\frac{X_2(s)}{Y(s)} = \frac{k_2}{m_2 s^2 + k_1 \left(1 + \frac{k_1}{m_1 s^2 + 1} \right) + k_2}$$

8. For the translational mechanical system shown in the figure below, the input is the displacement y of the right-end of the spring due to a force $f(t)$ is acting on the right most end of the spring to the right. The output is the displacement x of the mass. The spring is at its free length when $x = y$.

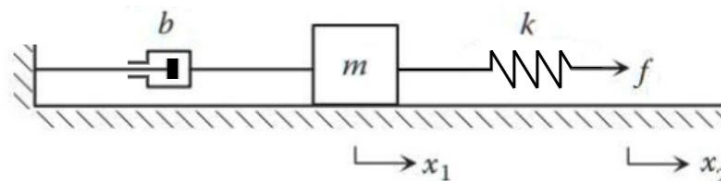

- Derive the equation of the motion for the system. [6 marks]
- Determine the transfer function equation of the system, $G(s) = X(s)/F(s)$, when $c = 4 \text{ N-s/m}$, $m = 5 \text{ kg}$, and $k = 5 \text{ N/m}$. [8 marks]

Solution

- The free body diagram in figure below displays only the horizontal forces. It has been drawn assuming that $y > x$.

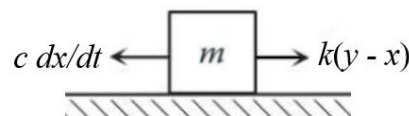

From this diagram, applying Newton's second law, we can obtain the equation of motion (assuming the direction is to the right-hand side):

$$m\ddot{x} = k(y - x) - c\dot{x}$$

Rearranging the equation above, thus:

$$m\ddot{x} + c\dot{x} + kx = ky$$

- b. Writing the equations of motion, where $y(t)$ is the displacement of the right member of spring, the equations for the system are:

$$(5s^2 + 4s + 5)X(s) - 5Y(s) = 0$$

And

$$-5X(s) + 5Y(s) = F(s)$$

Adding the two equations given above, the overall equation for the system becomes:

$$(5s^2 + 4s)X(s) = F(s)$$

From which, rearranging the equation as a ratio of $x(t)$ over $f(t)$, it is now:

$$\frac{X(s)}{F(s)} = \frac{1}{s(5s + 4)} = \frac{1/5}{s(s + 4/5)}$$

9. The resistor and inductor in the circuit shown in the figure below are said to be in parallel because they have the same voltage v_1 across them. Obtain the model of the current i_2 passing through the inductor. Assume that the supply current i_s is known. Derive Laplace transform of the circuit in terms of ratio of currents $I_2(s)/I_s(s)$. [10 marks]

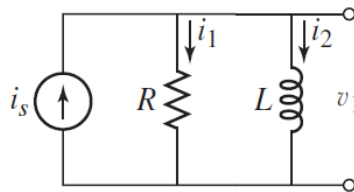

Solution

The currents i_1 and i_2 are defined in the figure. Then,

$$v_1 = L \frac{di_2}{dt} = Ri_1$$

From conservation of charge, $i_1 + i_2 = i_s$. Thus, $i_1 = i_s - i_2$. Substitute this expression into equation above to obtain:

$$L \frac{di_2}{dt} = R(i_s - i_2)$$

This is the required model. It can be rearranged as follows:

$$\left(\frac{L}{R}\right) \frac{di_2}{dt} + i_2 = i_s$$

Taking Laplace transform on both sides, the equation above becomes:

$$I_2(s) \left(\frac{L}{R} s + 1 \right) = I_s(s)$$

As a result, the transfer function equation for the system is:

$$\frac{I_2(s)}{I_s(s)} = \frac{R}{sL + R}$$

10. Find the transfer function, $G(s) = V_L(s)/V(s)$, for the network shown in the figure below. Solve the problem using mesh analysis. [16 marks]

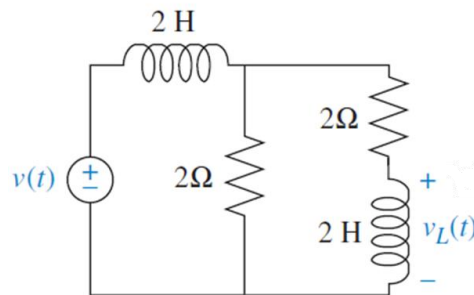

Solution

The following diagram outlines the equivalent circuit of the network given above.

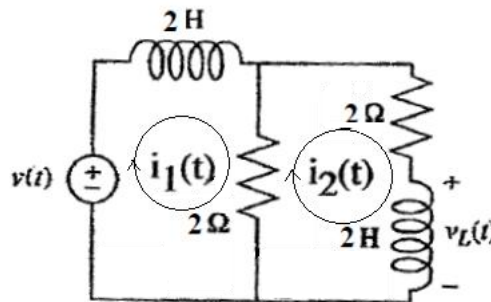

Writing the mesh equations, the equation for the left-hand side loop is:

$$(2s + 2)I_1(s) - 2I_2(s) = V(s) \quad (Eq. 1)$$

And the equation for the loop on the right-hand side is:

$$-2I_1(s) + (2s + 4)I_2(s) = 0 \quad (Eq. 2)$$

But, from the equation (2), the current I_1 is:

$$I_1(s) = (s + 2)I_2(s) \quad (Eq. 3)$$

Substituting equation (3) into the equation (1) yields:

$$(2s + 2)(s + 2)I_2(s) - 2I_2(s) = V(s) \quad (Eq. 4)$$

Rearranging the equation above, it becomes:

$$\frac{I_2(s)}{V(s)} = \frac{1}{2s^2 + 4s + 2} \quad (\text{Eq. 5})$$

We know that the voltage across the inductor is:

$$V_L(s) = 2sI_2(s) \quad (\text{Eq. 6})$$

Thus

$$I_2(s) = \frac{V_L(s)}{2s} \quad (\text{Eq. 7})$$

Therefore, substituting current I_2 in the equation (5) with equation (7), the transfer function equation for the circuit is:

$$\frac{V_L(s)}{V(s)} = \frac{2s}{2s^2 + 4s + 2}$$

11. Find the transfer function, $V_o(s)/V_i(s)$, for the inverting amplifier circuit given below.

[8 marks]

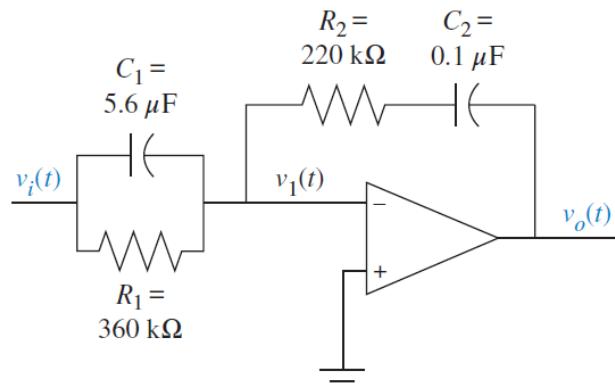

Solution

The transfer function of the inverting amplifier circuit is given by:

$$\frac{V_o(s)}{V_i(s)} = -\frac{Z_2(s)}{Z_1(s)} \quad (1)$$

Since the admittances of parallel components add, $Z_1(s)$ is the reciprocal of the sum of the admittances, or:

$$Z_1(s) = \frac{1}{C_1(s) + \frac{1}{R_1}} = \frac{1}{5.6 \times 10^{-6}s + \frac{1}{360 \times 10^3}} = \frac{360 \times 10^3}{2.016s + 1} \quad (2)$$

For $Z_2(s)$ the impedances add the components in series, or:

$$Z_2(s) = R_2 + \frac{1}{C_2 s} = 220 \times 10^3 + \frac{10^7}{s} \quad (3)$$

Substituting equations (2) and (3) into equation (1) and simplifying, we get:

$$\frac{V_o(s)}{V_i(s)} = -1.232 \left(\frac{s^2 + 45.95s + 22.55}{s} \right)$$

The resulting circuit is called a PID controller and can be used to improve the performance of a control system.

12. Given the electromechanical system and torque-speed curve as shown below, find the transfer function of the system, $\theta_L(s)/E_a(s)$. [20 marks]

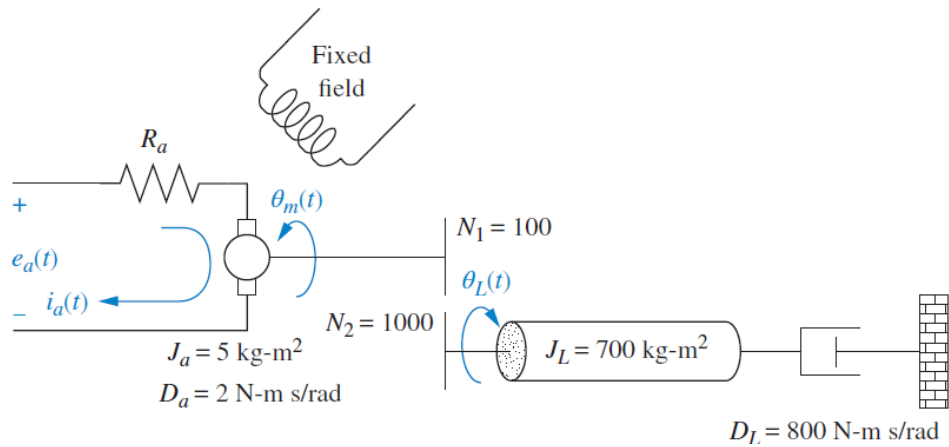

(a) Electromechanical system

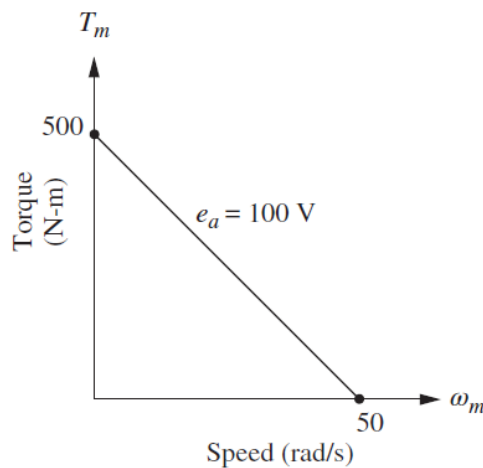

(b) Torque-speed curve

Solution

Begin by finding the mechanical constants, J_m and D_m , given in the following electromechanical equation shown below.

$$\frac{\theta_m(s)}{E_a(s)} = \frac{K_t/(R_a J_m)}{s \left(s + \frac{1}{J_m} \left[D_m + \frac{K_t K_b}{R_a} \right] \right)} \quad (1)$$

From the inertia of the armature of the motor equation of:

$$J_m = J_a + J_L \left(\frac{N_1}{N_2} \right)^2 \quad D_m = D_a + D_L \left(\frac{N_1}{N_2} \right)^2 \quad (2)$$

The total inertia at the armature of the motor is found to be:

$$J_m = J_a + J_L \left(\frac{N_1}{N_2} \right)^2 = 5 + 700 \left(\frac{1}{10} \right)^2 = 12 \quad (3)$$

Calculate the total damping at the armature of the motor:

$$D_m = D_a + D_L \left(\frac{N_1}{N_2} \right)^2 = 2 + 800 \left(\frac{1}{10} \right)^2 = 10 \quad (4)$$

Now we will find the electrical constants, K_t/R_a and K_b . From the torques-speed curve of figure (b),

$$T_{stall} = 500 \quad \text{and} \quad \omega_{no-load} = 50 \quad \text{and} \quad e_a = 100$$

Hence the electrical constants are:

$$\frac{K_t}{R_a} = \frac{T_{stall}}{e_a} = \frac{500}{100} = 5 \quad (5)$$

And

$$K_b = \frac{e_a}{\omega_{no-load}} = \frac{100}{50} = 2 \quad (6)$$

Substituting equations (3), (4), (5), and (6) into equation (1) yield:

$$\frac{\theta_m(s)}{E_a(s)} = \frac{5/12}{s \left\{ s + \frac{1}{12} [10 + (5)(2)] \right\}} = \frac{0.417}{s(s + 1.667)}$$

In order to find $\theta_L(s)/E_a(s)$, we use the gear ratio, $N_2/N_1 = 1/10$, and find:

$$\frac{\theta_L(s)}{E_a(s)} = \frac{0.0417}{s(s + 1.667)}$$

The block diagram of the system is as shown in the figure shown below.

