

XMUT315 Control Systems Engineering

Tutorial 5: Controllers and Compensators

A. Controllers and Compensators (Introduction)

1. Controllers and compensators are typically used for managing and controlling systems in control system.
 - a. Describe where controllers and compensators are used in control systems. [4 marks]
 - b. List three types of these controllers and compensators. [6 marks]
 - c. How can controllers and compensators change the characteristics and behaviours of the system? [3 marks]

2. List and describe various types of controllers or compensators in control systems in terms of their transfer functions, functionalities, and characteristics. [21 marks]

3. Given the following unity-gain feedback-control system as shown in the diagram below.

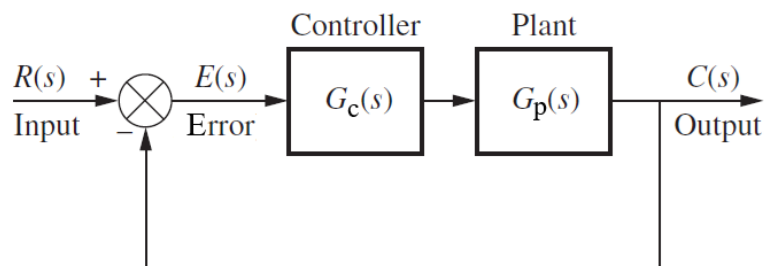

By using Bode plots, outline and describe briefly the frequency responses of the following controllers or compensators: [24 marks]

No	Controller/Compensator (C(s))	Transfer function
a	PD controller	$G_c(s) = T_D(s + 1)$
b	PI controller	$G_c(s) = \frac{1}{T_D} \left(\frac{T_D s + 1}{s} \right)$

c	Lead compensator	$G_c(s) = \left(\frac{Ts + 1}{\beta Ts + 1}\right) \quad \beta < 1$
d	Lag compensator	$G_c(s) = \alpha \left(\frac{Ts + 1}{\alpha Ts + 1}\right) \quad \alpha > 1$

4. Describe similarities and differences between the following controllers or compensators.
- Lead compensator and PD controller. [4 marks]
 - Lag compensator and PI controller. [4 marks]
 - Lead-lag compensator and PID controller. [4 marks]
5. The arrangement of compensator or controller is very important to be considered, so the modification and improvement that we wish to apply to the control system could be effectively and efficiently achieved.
- Outline and describe a variety of typically arrangements of the controller or compensator in the control systems. [12 marks]
 - Describe the differences between the arrangement of the controllers or compensators in the control system based on their flexibility in modifying the control system. [4 marks]

B. Controllers and Compensators (Application)

6. Given several control systems with the following transfer functions and the transient responses of the systems after given a step input:

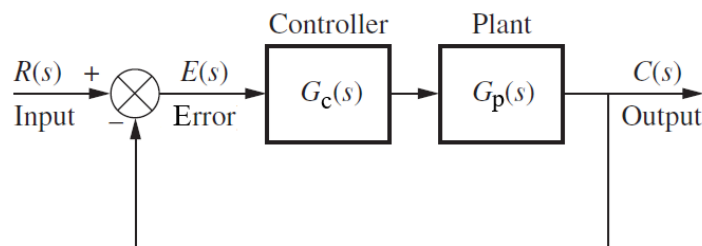

System	Transfer function of Plant ($G(s)$)	Transient response of the closed loop system after given a step input

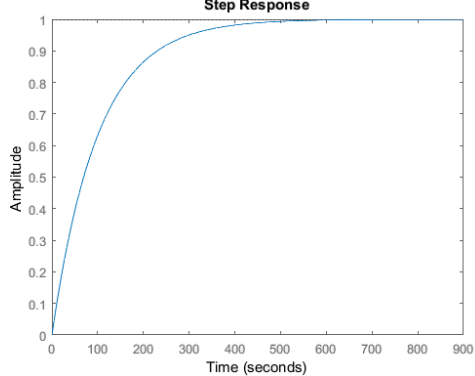
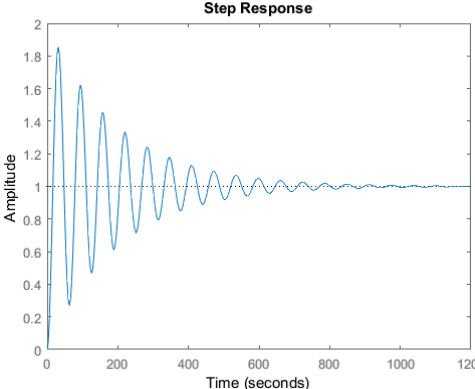
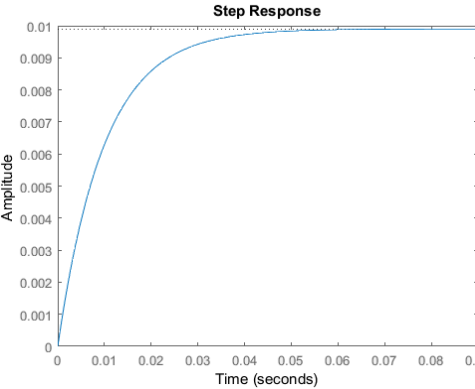
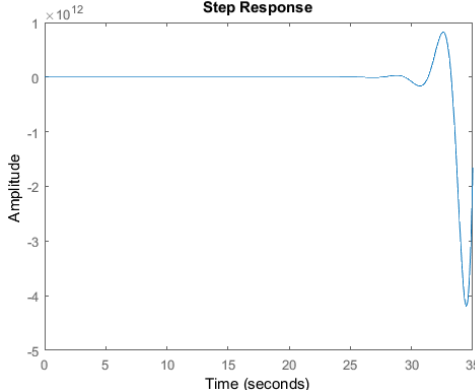
(i)	$G_p(s) = \frac{10}{s(s + 1000)}$	
(ii)	$G_p(s) = \frac{1}{s(s + 1)}$	
(iii)	$G_p(s) = \frac{1}{s + 100}$	
(iv)	$G_p(s) = \frac{7}{s(s + 0.1)(s + 0.2)}$	

By referring to the table shown above, we can conclude that the systems listed above are experiencing some problems.

- a. Describe the problem that each of the systems is experiencing. [8 marks]
- b. Suggest a controller or compensator that would fix each of the problems. [8 marks]

7. A typical electric network of a lead compensator is as shown in the figure below.

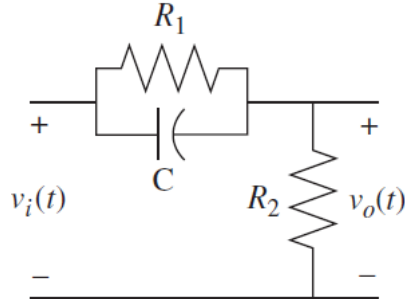

- a. Determine the transfer function equation of the lead compensator in terms of the values of the components in the electrical network. [12 marks]
- b. When $\alpha = 0.5$ and $T = 5$, determine the values of the resistors R_1 and R_2 and capacitor C in the electrical network. [4 marks]

8. The electric network circuit of a lag compensator is as shown in the figure below.

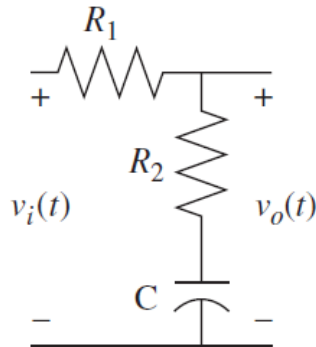

- a. Derive the expression for the lag compensator in terms of the values of the components in the electrical network given above. [12 marks]
- b. Like part (a), derive the expression for lag compensator in the pole-zero form. [6 marks]
- c. For the following transfer function equation of a lag compensator, determine the values of the components in the electrical network. [6 marks]

$$G_c(s) = \frac{0.1s + 5}{2s + 2}$$

9. Describe how a proportional (P) controller with a proportional gain (K_p) of 2.5 is implemented in practice. Consider E12 standards and the open loop gain of the op amp is 8×10^5 . [6 marks]

10. For an implementation of a given PID controller using operational amplifier in practice:

- a. Outline the process for designing the PID controller using an op amp-based circuit.

[12 marks]

- b. How do you modify the op amp-based circuit for PID controller as in part (a) to be a circuit for PI controller? [6 marks]

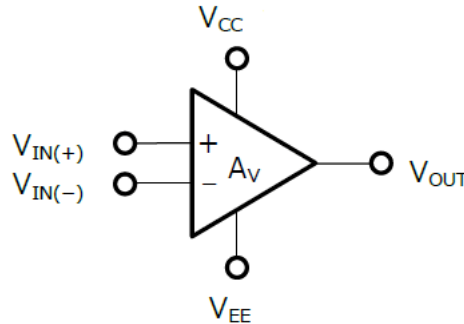

11. Tuning a controller or compensator is required for optimal operation of a controller or compensator in control systems.

- a. Describe what is tuning for a controller or compensator. [2 marks]

- b. For a given controller or compensator, list three types of tuning method. [6 marks]

- c. Describe how you tune in a PID controller using Ziegler-Nichols rule. [6 marks]

C. Controllers and Compensators (Analysis)

12. This case illustrates the application of gain controller in a given control system. Consider a servo control system as given in the block diagram below. Perform the following tasks:

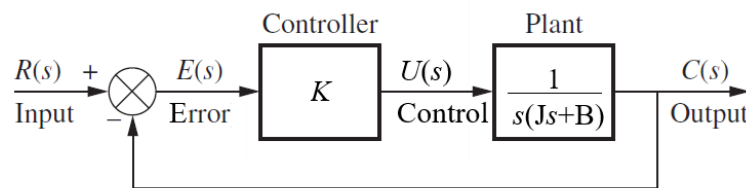

- a. For the steady-state error analysis, determine the steady-state error of the system to unit ramp input. [8 marks]

- b. For the transient response analysis, derive equation for damping ratio of the system. [6 marks]

- c. Evaluate whether proportional controller would meet the desirable steady-state and transient response behaviours. [4 marks]

13. For a proportional-derivative (PD) controller implemented in a given control system shown below.

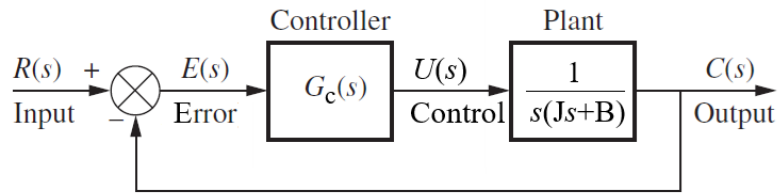

Controller transfer function $G(s) = K_p + K_D s$, where K_p is the proportional constant, and K_D is the derivative constant. It is expected that the inserted PD controller could improve the steady-state error to unit ramp and the transient response will have damping ratio $0.5 < \zeta < 0.8$.

Perform the following tasks:

- For steady-state error analysis, would it be possible to make steady-state error to a unit ramp using the proportional controller of the given controller? [6 marks]
 - For transient response analysis, derive the equation for the damping ratio of the system. [6 marks]
 - Suggest the setup of the PD controller for the given system that will meet the stated design specifications. [4 marks]
 - Discuss feasibility of PD controller for the improving the control system. [2 marks]
14. For a given implementation of tachometer as a controller, we design a rate feedback (tachometer) control as shown below.

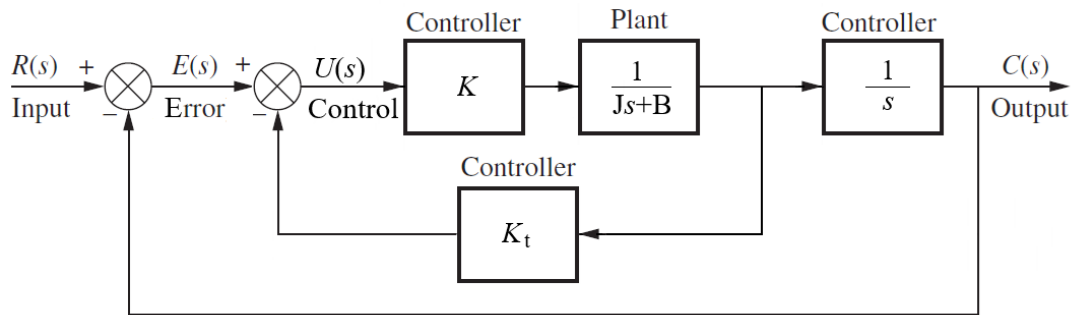

Alternatively, the above block diagram can be reduced as shown below to the typically used tachometer control system. α

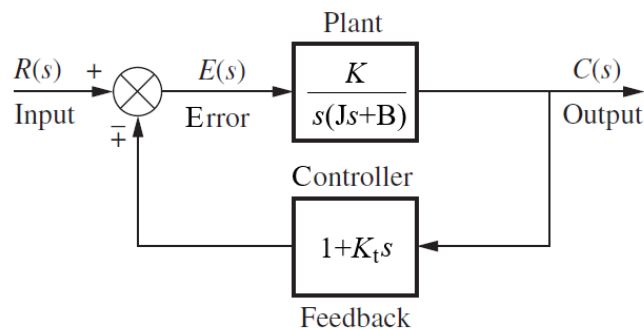

For the given system, perform the following tasks:

- For the steady-state error analysis, determine whether the given control system can reduce the steady-state error to unit ramp. [6 marks]
- For the transient response analysis, suggest the setup of the control system, so its steady-state error to unit ramp is improved and damping ratio between $0.5 < \zeta < 0.8$. [8 marks]

15. For the tacho control system given below, attempt the following tasks:

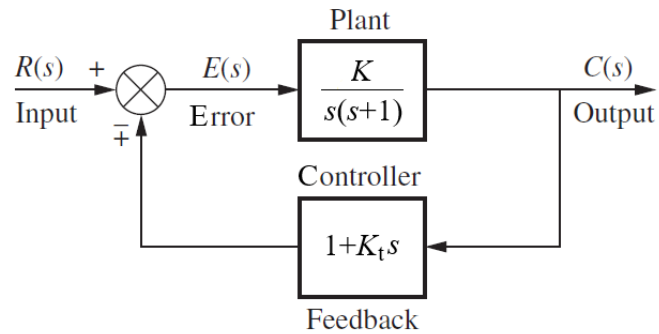

- Find K and K_t such that maximum overshoot, M_p , to unit step is 0.2 and time-to-peak is 1 second. [10 marks]
- Then, using these values of K and K_t obtained in part (a), determine the values of rise time (T_r) and settling time (T_s). [4 marks]